

# The role of the serotonin system in ADHD

*Robert D. Oades*

Clinic for Child and Adolescent Psychiatry and Psychotherapy, Virchowstr. 174, 45147 Essen, Germany. Email.: [robert.oades@uni-due.de](mailto:robert.oades@uni-due.de)

## **2007 Expert Review of Neurotherapeutics 7, 1357-1374.**

(This is the reformatted manuscript submitted - prior to publication in its final form: PMID: 17939772)

### **Abstract:**

A limited number of studies have considered whether the activity of serotonin (5-HT) contributes to the problems experienced by youngsters with attention-deficit hyperactivity disorder (ADHD). The aim here is to review this work and propose interpretations. Peripheral measures of 5-HT and its metabolite do not point to a widespread association with the diagnosis. However, separate consideration of the major domains of dysfunction (motor activity, inattention and impulsivity) support a more differentiated assessment. The marked innervation of motor regions of the brain by 5-HT projections and the clear involvement of 5-HT systems in the control of locomotion in animals suggests a likely node for dysfunction in ADHD. The few relevant studies do not bear this out: but more attention should be accorded to the issue. The situation is different for attention-related processes. Here there are deficiencies in perceptual sensitivity and the appropriate designation of saliency to stimulation. These are attributable in part to altered 5-HT activity. Marked and opposite changes of 5-HT responsivity are associated with behavioral and cognitive impulsivity. There is also a growing series of studies demonstrating preferential transmission of various genetic markers for 5-HT receptors that are expressed in ADHD. Currently the heterogeneity of methods in this young discipline restricts the possibilities of definition of these markers and the types of ADHD in which they are expressed.

**Keywords:** ADHD, attention, genetics, glia, impulsivity, motor, neurotrophin, serotonin.

**Abbreviations:** ADHD, attention-deficit/hyperactivity disorder; CNS, central nervous system; CPT, continuous performance test ; CSF, cerebrospinal fluid; DA, dopamine; ERP, event-related potential; fMRI, functional magnetic resonance imaging ; 5-HIAA, 5-hydroxyindoleacetic acid; 5-HT, serotonin; 5HTT, serotonin transporter; HVA, homovanillic acid ; MMN, mismatch negativity ; NA, noradrenalin; SHR, spontaneously hypertensive rat

### **Introduction:**

Currently there is consensus that the best pharmacological treatments available for patients with attention-deficit/hyperactivity disorder (ADHD) with clinical impairment include one or another formulation of the psychostimulants (methylphenidate, amphetamine) or the noradrenergic reuptake inhibitor atomox-

etine [1, 2]. A good clinical improvement in about 70% of patients on one of the psychostimulants rises to >80% after treatment with the other [3]. This mark is difficult to better in psychopharmacology. But that still leaves at least 20% who are non-responders. Further, for many "responders" clinical improvement may not extend beyond c. 25-30%, and

the youngsters' academic impairment may show no long term improvement at all. As the 'Multimodal Treatment' study showed, the positive effects of medication may continue for some months, but can deteriorate markedly over 2 years [4].

Thus, a significant minority do not respond to catecholamine uptake inhibitors, and where response is achieved there remains a situation where the symptoms are relieved but the cause may be left untouched. Is it possible that serotonin (5-HT) could play a role in moderating (persistent symptoms) or even mediating features of a nervous system that make it vulnerable to ADHD? Twenty years ago evidence for the catecholamine contribution was strongly emphasized and that for 5-HT rejected [5, 6]. But the scene may be changing. This review aims to gather data to show that 5-HT systems play a role in ADHD and that there is a need to improve our understanding of this. This article describes many of the pieces to the puzzle, but the picture remains one of an incomplete jigsaw.

### Serotonin Systems

At first, it would seem that 5-HT has at the same time both good and bad prospects of being a candidate for a role in ADHD. Neural projections of 5-HT systems innervate nearly every part of the fore- and mid-brain, and descend in the dorsal and ventral horns [7]. There are receptors even in the cerebellum [8, 9]. Peripherally there is an extensive innervation of the gut, the lungs, the kidney and smooth muscle systems. It is not surprising then that 5-HT is implicated in most of the major domains of function [10]: e.g. cardio-vascular function, respiration, sleep, aggression, sex, feeding, anxiety, mood, cognition, motor output, hormone secretion and nociception). In the CNS 5-HT affects not

only neurons, but astrocytes and oligodendrocytes too [11]. Early in foetal development 5-HT also has a neurotrophic function (e.g. maternal levels influence the foetus, [12]), with transmitter function developing later in a crucial period in late pregnancy and early infancy.

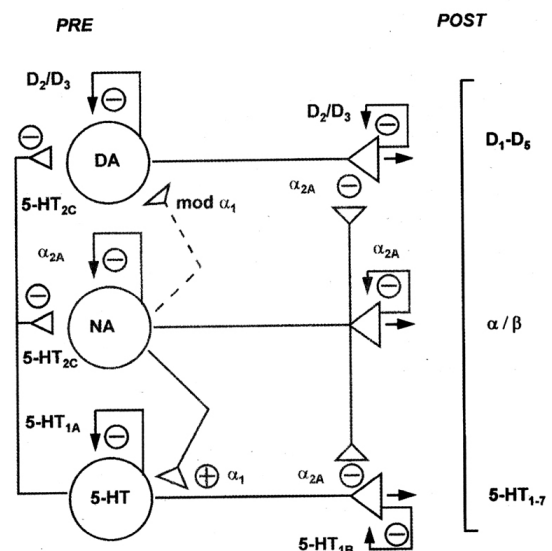

**Figure 1:** Simplified scheme of relations between 5-HT, DA and NA transmission in the frontal cortex emphasizing the presynaptic level. Note the regulation of DA and NA cell bodies by tonic 5-HT innervation (via 5-HT<sub>2c</sub> sites) from the dorsal raphe. The 5-HT neurons express 5-HT<sub>1a</sub> sites at the cell body and 5-HT<sub>1b</sub> sites at the terminals [185]. (Note that an excitatory influence of 5-HT<sub>2A</sub> receptors is probably expressed at the level of DA and NA terminals. The inhibitory influence of 5-HT<sub>2C</sub> receptors on DA and NA cell bodies may be indirect, via activation of GABAergic interneurons. Reproduced from [185] with the permission of Elsevier.)

Fortunately there are many features that can be used to determine a degree of specificity of function and alterations to one or another part of the networks involved. Pharmacologically speaking there are about 22 types of 5-HT receptors. A simplified scheme for the main actors in the present discussion and their interactions with other monoamine systems is shown in figure 1. Anatomically

the projecting fibres may be fine with small varicosities or thick with larger beaded varicosities [13: Fig. 2]. A few even lack varicosities. Their innervation patterns overlap, though the former are widely distributed, and the latter less so with a preferential frontal and hippocampal distribution. Cortical terminals are located on stellate cells in layer I, and bipolar cells in layers II and III. However, in the visual (and auditory) sensory cortices – where the innervation is more intense than in secondary areas - 5-HT fibres innervate layer IV that receives input from the lateral geniculate (and inferior colliculus) relays [10, 14].

5-HT neurotransmitter systems derive from 9 cell groups stretching in the midline from the pons to the caudal medulla (B1-9). B1-5 project locally and down the spinal cord. Central to the innervation of the CNS are the dorsal raphe (B6/7: on the floor of the fourth ventricle) and the more ventral median raphe (B8: on the pons/midbrain border). Between them these nuclei innervate most areas with an overlap, although the median raphe is biased towards an innervation of limbic and parietal regions, and the dorsal raphe to an innervation of fronto-striatal regions [7, 13, 15].

#### **Indicators of relevance of 5-HT to the ADHD syndrome:**

Clearly 5-HT can act a) as a transmitter in most parts of the CNS (above) or b) as a paracrine modulator affecting neurons and glia alike (as a large proportion of terminals are without conventional synaptic contacts [16]), or c) exert neurotrophic effects on growth and development. From first principles one cannot easily pick out a key node likely to contribute to the main dysfunctions in ADHD.

Are there any signs that 5-HT metabolism in youngsters with ADHD is unusual? Peripheral signs must be

considered as ethical concerns prevent the use of intracranial probes or radioactive ligands for neuroimaging. Clearly such measures (e.g. CSF, blood, plasma, urine) will reflect the large contribution of somatic sources, and opinions differ widely on their utility. But so long as the subjects are physically healthy there is little reason to suspect a differential contribution from peripheral and central sources. However, it should be noted that use of such measures assumes,

*i.* the development of pathological features affecting 5-HT would influence peripheral and central metabolism similarly,

*ii.* the blood brain barrier that blocks entry and actively transports the relevant substances out of the brain is intact,

*iii.* transmitter metabolism contributes to the behaviours recorded:

lastly, it should be acknowledged that the age or stage of development of all of these components may confound the interpretations of the nature of the relationships sought and found [full discussion in 17].

In three reports comparing groups of ADHD with healthy children (or norm values) on blood 5-HT levels a decrease was reported in two (95 patients [18, 19]) and no change in one (49 patients [20]). No changes were reported for platelet levels in 55 patients [21], while plasma levels were decreased in 35 patients showing many rather than few symptoms [22].

For three reports on CSF levels of the metabolite 5-hydroxyindoleacetic acid (5-HIAA) no differences were recorded for 30 patients [23, 24], - not even when 29 patients were compared to those with conduct disorder [25]. (CSF levels might be expected to be biased towards sources in the spinal cord.) This lack of a

difference between groups was confirmed for platelet levels in 17 patients [26] and urine levels in 17 patients [27]. However, comparisons of the metabolite with 5-HT

levels (an indicator of utilization) in studies of urine showed a trend towards an increase of activity [28, 29].

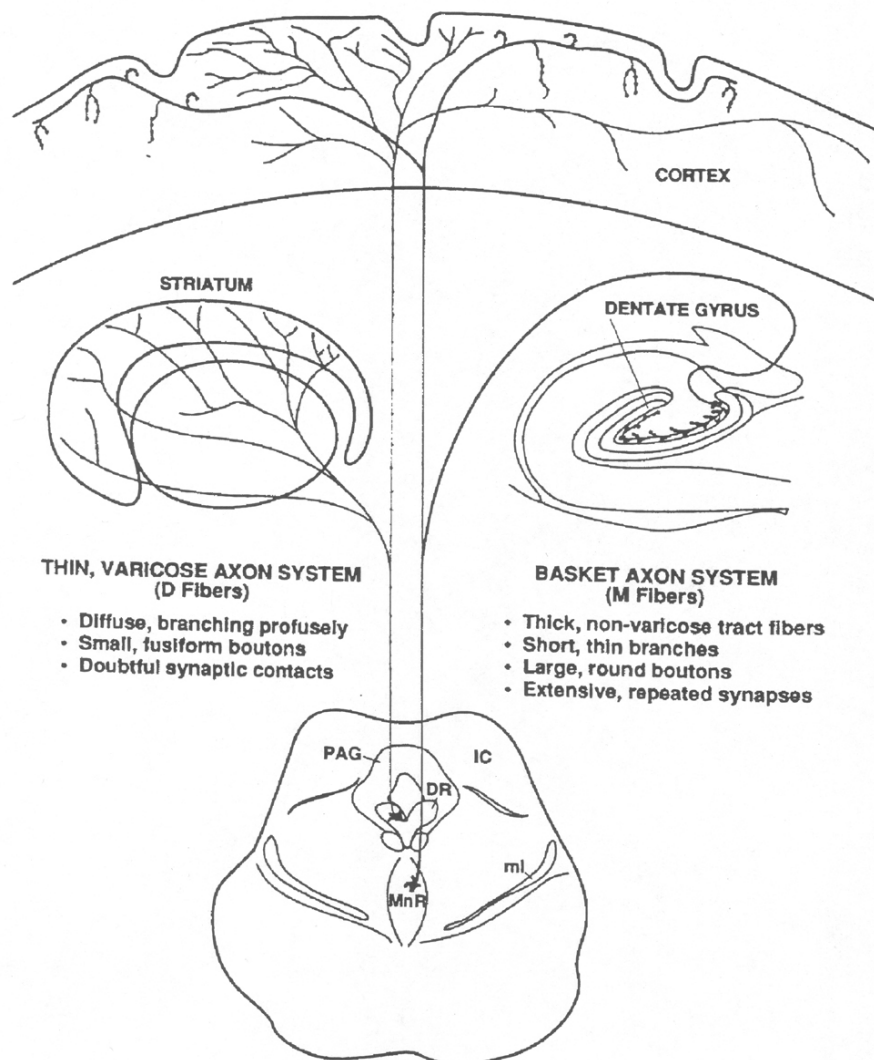

**Figure 2:** A simplified summary diagram of the principle histological features of the two main serotonergic pathways ascending to the forebrain. On the left, from the dorsal raphe (DR) the projections provide the major innervation of the neostriatum: on the right, from the median raphe (MnR) are the fibres that provide the major innervation of the hippocampus. There is considerable overlap in the neocortices, although coexistence may occur in most brain regions (Reproduced from [13] with the permission of Blackwells Publishing.)

Despite hints that some patients might show increased 5-HT metabolism, there is no clear indication that the ADHD syndrome is associated with alterations of 5-HT metabolism. There are three reasons why this should not surprise. First patients

were sampled before and during adolescence when large developmental changes would be expected. We have found that healthy children excreted twice the levels of 5-HT and its main metabolite found in young adults, although the

utilization measures were similar [30]. In contrast early and late adolescent groups showed depressed levels of activity with highly variable measures of the metabolite 5-HIAA in late adolescence. Second, the measures reported in the ADHD studies make no reference to the activity of other neuronal systems, particularly those using dopamine (DA) and noradrenaline (NA) with which there are many well-documented interactions (in both directions). Considering the role of the catecholamines in ADHD and reported correlations of metabolite measures (e.g. HVA with 5-HIAA: [17, 25]) the absence of comparisons of the metabolites is surprising. In fact the only example describes the 5-HT system as hyperactive in comparison with the DA system [31]. Third, considering that ADHD covers inattentive, impulsive and motor activity symptom domains, among other anomalous features, it would be surprising if there was a unifactorial association with diagnosis. The domains of impairment cover the functions of a number of brain regions. Across a patient population anomalies are likely to be distributed unevenly.

Central to present considerations are effects of 5-HT on the expression of attention/ inattention, impulsivity and motor activity. Genetic studies are considered separately, below.

### ***Motor Matters:***

Increased motor activity and restlessness is a cardinal feature of the combined and hyperactive-impulsive subtypes of ADHD. One notes the use of the term hyperkinetic syndrome by the World Health Organization. Indeed, there is a major projection of the 5-HT system to both the primary and secondary motor cortices and 5-HT activity facilitates gross motor output [10]. Yet remarkably few human studies have been directly and

specifically concerned with the 5-HT/locomotor relationship.

In animals increases of extracellular DA, whether brought about by treatment with amphetamine [32] or genetically knocking out the DA transporter [33], are associated with increases of locomotion. In both instances the motor effects can be controlled by treatment with a 5-HT<sub>2a</sub> receptor antagonist. Blockade of receptors for glutamate, by far the most abundant transmitter in the forebrain, also results in hyperactivity. The importance of the modulatory role of 5-HT is shown by the ability of 5-HT<sub>2a</sub> antagonists to enhance the attenuation of locomotion induced by the antipsychotic risperidone following glutamate blockade [34]. As a counterpoint to this, hyperlocomotion can be elicited by 5-HT presynaptic agonism [8-OH-DPAT], and blocked at the 5-HT<sub>1a</sub> receptor [35]. Both the amphetamine and the knockout paradigms have been referred to as models for ADHD. But what is known about the role of 5-HT in the arguably best animal model for ADHD, namely the hyperactive and spontaneously hypertensive rat (SHR)?

I am not aware of directly comparable studies. However the reduction of SHR exploration in an elevated plus maze by a 5-HT reuptake blocker (citalopram: [36]) suggests that the baseline situation in the SHR differs from the models just mentioned. (But it should be noted that in a similar study with fluoxetine the WKY-controls explored even less and showed decreases of transmitter, transporter and cortical 5-HT<sub>2a</sub> binding [37]). However, Stocker et al. [38] suggested that the SHR was in fact less sensitive to reuptake blockade as these animals showed a blunted prolactin response in a challenge test. Unfortunately, there are further examples of strain differences in the

sensitivity of the 5-HT system. While frontal cortical 5-HT turnover was reported to be lower in the SHR than in WKY rats [39], a much larger increase of turnover in the frontal regions after blocking monoamine oxidase B was described for the SHR than the WKY [40]. These studies reported no clear changes in the basal ganglia, but relative decreases were found in the brainstem [39] – and these decreased further if animals had prolonged access to a running wheel [41]. In comparisons with rats of the Lewis strain SHRs are reported to be less physically active when challenged (e.g. plus maze, swim test). Postmortem analyses showed that cortical 5-HT<sub>2a</sub> binding either did not differ [42] or increased rather more in the Lewis strain: at the same time 5-HT<sub>1a</sub> binding decreased much more in the hippocampus of the SHRs [43].

One must conclude that there is a great deal of basic research on the SHR model still needed<sup>1</sup>. Even if the evidence is not entirely satisfactory, there seem to be subtle indicators that the sensitivity of the 5-HT neuronal system differs in the SHR model, especially under challenge. That is crucial, for patients with ADHD are not hyperactive all the time. But it may be noted that the review of animal models by Russell et al [44] finds little support for “a role for serotonin in the aetiology of [such] ADHD symptoms in SHR”.

Whether reflecting cause or effects, CSF records of 5-HT activity (5-HIAA) in healthy free-ranging primates are associated with night- (negatively) and day-time behavioural activity (positively: [47]). In a rare study of the CSF of ADHD children, Castellanos et al. [25] reported

that measures of HVA and 5-HIAA were inter-correlated as were urinary and CSF sources. In these children both HVA and the ratio HVA/5-HIAA correlated positively with ratings of behavioural hyperactivity on the Conners’ scale. Severity of the symptom and high levels of the metabolites predicted a good response to medication, when all the metabolites showed a decrease [48]. While this may point to a major role for DA metabolism, it supports an interactive and modulatory role for 5-HT metabolism in line with the ratios reported above to be associated with the syndrome [28]. Clinical trials have rarely used either serotonergic substances or taken measures of 5-HT responsiveness. But it may be noted that a) fenfluramine treatment (5-HT release) of children with autism or ADHD reduced behavioural activity [49], b) a trial of buspirone (5-HT<sub>1a</sub> agonist) resulted in an improvement in most domains, expressly including hyperactivity [50], and c) imipramine (non-selective uptake inhibitor) has often been associated with a good response, especially in children not improving on psychostimulant treatment [51]. However, the reader will be aware that each of these agents has other well-known catecholaminergic effects that may well account for some of the behavioural changes recorded<sup>2</sup>. In conclusion, 5-HT activity modulates “motor matters”, but in ADHD its role may be contributory rather than predominant.

### ***Attention/inattention:***

The term ‘attention’ has a broad range of meanings in psychiatry, and is often dubbed a ‘cognitive activity’. In mainstream psychology attention is the

<sup>1</sup> I should remark that it is the *young* SHR (prior to the expression of hypertension) that should be used as a model for ADHD. Not all reports state the stage of development studied precisely. 5-HT is clearly involved in the brainstem regulation of hypertension in adult animals [45, 46].

<sup>2</sup> For comparison, psychostimulants may alter 5-HT activity indirectly via their direct influence on catecholamine systems, but direct effects of methylphenidate on 5-HT systems do not occur, and those of amphetamine are found only at pharmacological doses [52].

“selective aspect of perception” [53]. It is generally accepted to consist of early ‘automatic’ and later ‘controlled’ processes [54] that roughly translate as pre- and post-conscious processes [55]: the cognitive or executive function being more evident in the latter. (The term ‘pre-attentive’, as used by some psychophysicists, can be traced back 40 years [56] and alludes confusingly to stimulus-driven selective information processing occurring before attention). Attention can most easily be construed in terms of exogenous selection, in terms of a subject’s responsivity to some but not other stimuli. Clearly controlled processes involve endogenous selective (often ‘top-down’) influences that occur between the activities of separate regions of the brain.

Selection of incoming/ascending sensory information is strongly influenced by the availability of resources, competition and the saliency of the information. Top-down processes – located more anteriorly - require capacity and effort. The ability to sustain attentional processing is largely a property of the right hemisphere [57]. Where could 5-HT come in? Through its regulatory (usually inhibitory) control of the activity of catecholamine (and other) neurons, at a neurophysiological level, it exerts a homeostatic role that can be described as “setting the tone”, at a system level [14, 58]. Functionally this can be viewed as a form of ‘volume-control’ or ‘gain’ that, as these authors suggest, must work in conjunction with prevailing levels of activation or arousal. (This model contrasts with a ‘tuning’ or ‘switching’ mechanism attributed to NA and DA, respectively [59]). Thus salient stimuli, at both the perceptual or physiological level, are likely to evoke responses in the 5-HT system. Together, with the evidence for the involvement of genetic variants of 5-HT synthesis and transport in the

expression attentional abilities [60], one anticipates a role for 5-HT systems in the characteristics of attentional function shown by those with ADHD.

### ***5-HT and exogenous attention:***

Let us take the example of an auditory stimulus. As the information ascends in the brain, it will be influenced by 5-HT activity in the inferior colliculus [61], the primary, and then the secondary auditory cortex – with more and less 5-HT innervation, respectively. Event-related potentials (ERPs) recorded from the scalp can distinguish the contribution of the latter regions to the N1 and P2 responses elicited after 100-200 ms. Sources in primary regions are characterised by a tangential dipole sensitive to sound intensity, whereas the radial dipole in secondary areas is not [62]. If the sound is salient, the excitatory N1 is large, and if the sound should be further processed then the inhibitory P2 marks the suppression of the processing of competing stimuli [63, 64]. With increasing loudness the N1-P2 amplitude increases.

With increased 5-HT activity sound intensity dependence is reduced (e.g. following reuptake block with zimelidine or treatment with lithium or alcohol). The slope of the loudness dependency curve is steep if 5-HT levels are low - reflecting utilization, but shallow or flat if 5-HT levels are high and 5-HIAA levels are low [65]. Decreased responsiveness and a weak loudness dependency is seen in individuals homozygous for the long allele of the 5-HT transporter promoter compared to those with the short allele [66]. It is this long allele which has been associated with ADHD in 4 studies [e.g. 67, but see 68 and the genetics discussion below]. The nature of the relationship of 5-HT activity to auditory processing is not undisputed. For example, treatment with the selective reuptake blocker citalopram

may [69] or may not be associated with the slope of loudness dependency [70]: see discussion of the two groups [71].

However, in view of the controversy on how 5-HT influences these ERP markers of auditory processing it is interesting to note that use of the tryptophan-depleting drink altered the dipole strength [72]. Only the tangential dipole was affected (i.e. the primary cortex) and only in the right hemisphere. This treatment has also been claimed to increase the ERP marker of auditory change detection in the latency period of 100-200 ms after the stimulus (the mismatch negativity, MMN: [73]). As MMN normally develops in children initially in the right hemisphere, but is anomalously recorded in ADHD cases first from the left hemisphere [74] the potential for a role of 5-HT activity should be directly investigated.

The reader may be forgiven here for wondering if too much or too little 5-HT activity may be at the root of the type of stimulus processing described. Each of the above cited studies is confounded by factors such as not knowing whether the uptake block really increased 5-HT neurotransmission, or whether the genetic make up of the subjects tested included those with or without the more active transporter promoter. Nonetheless, the involvement of 5-HT is worth close investigation as the augmenting response has been used to predict clinical response to 5-HT agonists in patients with affect disorders [75]. Further, with regard to the ERPs of those with ADHD, there are numerous studies that report an unusually large P2 component where these patients are involved in stimulus choice and comparison [74,76,77]. This has been interpreted as showing the suppression of the processing of competing information by a non-salient stimulus. This is an explanation of how a stimulus not

relevant to ongoing activity can distract or 'grab' attention: In other words the use of 'gain' or volume control (through inhibitory 5-HT activity) where it is not adaptive. This concept can be extended in the next sections on endogenous attentional processes and later on impulsivity.

### ***5-HT and endogenous attention:***

Youngsters with ADHD have long been known to show impaired sustained attention in terms of top-down controlled discrimination [78,79], and in the ability to switch between attentional sets [80,81]. In the former one observes decreases of the signal detection indicator, d-prime, that reflects whether the stimulus has been perceived, while in the latter the response latency costs of switching from responding to (say, in the trail making test) letters, then numbers is abnormally increased. Here the discussion is not concerned with the evidence that DA activity is important, but that 5-HT activity can play a significant role.

In the previous section we noted that registering a *change* in auditory stimulation (MMN) may be influenced by 5-HT innervation. In the right inferior frontal cortex there is an MMN dipole source [82] involved in the switch from processing repeated stimuli to the potentially significant new salient one [83]. Smith et al. [84] showed with fMRI that this region was activated by switching between left and right in accord with arrows on a screen (Meiran test). The same group reported that activation of this region during switching is markedly decreased in subjects with ADHD [85] and that administering a tryptophan-depleting drink (to reduce 5-HT synthesis) to healthy young people performing the same task also decreased activation in this region [86: fig. 3]. The evidence for an alteration in 5-HT function in ADHD cases being



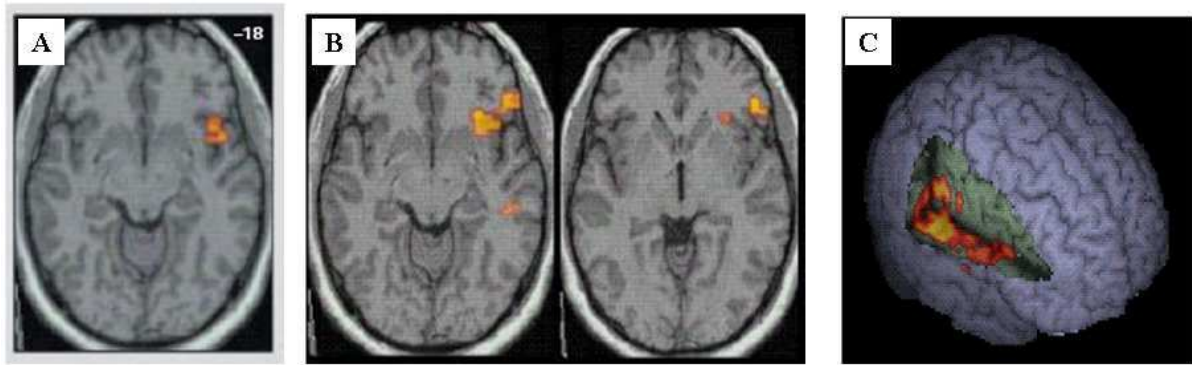

**Figure 3**

F-MRI studies of switching between response and non-response or between types of responses: **A/** Less right inferior frontal activation in ADHD even when responses were successfully inhibited [85]. **B/** Right inferior frontal activation in sham condition not seen in tryptophan depletion condition on switch to no-go vs. go trials in healthy young people [86]. **C/** Less activation in a system from right inferior frontal to parietal and temporal regions in ADHD vs. control subjects on switch vs. repeat trials according to arrows [87]. (Modified after [84, 86, 87] and reproduced with the permission of the American Psychiatric Association)

involved in an impairment of switching task performance is indirect but striking.

In continuous performance tests (CPTs) of sustained attention fMRI studies show activation on the right particularly in regions of the prefrontal cortex similar to those just described as part of the “anterior attention system” of healthy subjects [88]. Healthy, but poor performers have been reported to show less activation of such prefrontal regions on the right [89]. On a CPT a good proportion (but not all) of ADHD cases will respond positively to treatment with imipramine (a non-selective 5-HT and NA uptake blocker). The responders may show not only improved CPT performance but also a significant tendency towards normalization of their cortical EEG, that prior to treatment showed signs of immaturity [51]. Again the evidence for the role of 5-HT in ADHD is indirect, but the pieces of the puzzle fit.

Oades [79] described a series of visual CPT tests on most of which d-prime was impaired in those with ADHD. Two features were associated with the impairment. First the impairment was

attenuated by providing feedback<sup>3</sup>: second poorer performance related to increased 5-HT metabolism, particularly with respect to DA activity (Fig. 4). This relative increase of 5-HT metabolism was also reported to be related to improved conditioned blocking [28]. But as conditioned blocking is about not attending to and learning about a stimulus that is redundant and thus irrelevant to the ongoing task, one suspects that this could also have been the result of poorer perceptual abilities and a decreased d-prime.

Of course attention-related function may not only be influenced by the

<sup>3</sup> The role of feedback has particular interest. Psychophysicologists report on error-related negativity and positivity in the ERPs monitored during CPT-like tasks. Some report decreases of these ERPs in those with ADHD [94, 95]: although depending on the sample and performance, the opposite has been reported [96]. In contrast, such error-related responses are enhanced in patients with obsessive compulsive disorder [97] and in students who displayed fewer traits of impulsivity [98], - conditions with established associations with 5-HT metabolism. The implications of these results are not only that there may be a 5-HT influence on attention to feedback, but that the response and attention to feedback can be improved with salient exogenous feedback.

utilization of 5-HT, but also by its availability. There are indications that 5-HT synthesis can also be impaired in ADHD and is related to polymorphisms of the TPH2 gene [see genetics section: 90-92]. The presence of this polymorphism is also related to slow reaction times, its variability and errors of omission made by those with ADHD [93]. In conclusion 5-HT appears to moderate attention-related processes, and this influence overlaps conceptually with the impulsive treatment of stimuli and organization of response, a notable feature of ADHD discussed in the next section.

### **5-HT and impulsivity:**

To those not directly concerned with ADHD the concept of impulsivity is linked strongly to outbreaks of aggression, increased 5-HT<sub>2a</sub> platelet binding (B<sub>max</sub> and K<sub>d</sub>), decreased 5-HT<sub>1a</sub> binding [99] and low 5-HT activity [reviews: 100, 101]. Of course such abrupt outbursts can be a feature of ADHD, particularly when a conduct disorder is also present. But here I am also concerned with the hasty decision that led to a mistake, a so-called error of commission. Such errors are commonly made by younger [102] and older subjects [103] with ADHD. They are frequently measured in CPT-like laboratory tasks such as the Go/no-go, and are well illustrated in the Stop-Task and in flanker tasks where adjacent incongruent stimuli distract from the direction of response required by a target arrow.

Impulsivity has been briefly and broadly defined as “action without foresight” [104]<sup>4</sup>. These authors, as others before them [106], are well aware of (at least) two categories of impulsivity. There

is less appreciation of the increasing likelihood of these two categories reflecting opposite tendencies in central 5-HT activity. I shall call these categories behavioural (aggressive) and cognitive impulsivity.

To underscore the separation of these two types of impulsivity, we have recently performed a factor analysis (with oblique rotation) of impulsive symptoms rated on the Conners parent and teacher rating scales from 776 combined type cases of ADHD (Lasky-Su and Oades unpublished results) in an ongoing genetic study [107]. The scores neatly divided into behavioural impulsivity (e.g. temper outbursts and tantrums, disturbs or fights, argumentative behaviour) and cognitive impulsivity (e.g. distractible, not think things out before acting, fails to finish things). Each category explained some 28% of the variance.

The *expression* of aggression in children has been associated with decreases of CSF levels of 5-HIAA taken at birth [108], (that in turn can correlate with postmortem levels in the frontal lobes [109,110]). But it is the opposite in cognitive situations. In a treatment study of ADHD children it was the ability to *inhibit* on the ‘stop-task’ that correlated with decreased plasma 5-HIAA [111]: (for correlations between peripheral and CSF levels see [25]).

This dichotomy between behavioural and cognitive impulsivity is illustrated within one study [112]. 5-HT transporter affinity was measured with paroxetine in platelets from 20 children with ADHD. (The system in platelets closely models that in the CNS [113].) While increased transporter affinity (a low K<sub>d</sub>) tended to correlate with aggressive and externalising behaviour rated with the child behaviour check list (CBCL), decreases of transporter affinity (increased K<sub>d</sub>) were well correlated with a

---

<sup>4</sup> The term impulsivity covers actions that appear poorly conceived, prematurely expressed, and are unduly risky or inappropriate to the situation. They often result in undesirable consequences [105]

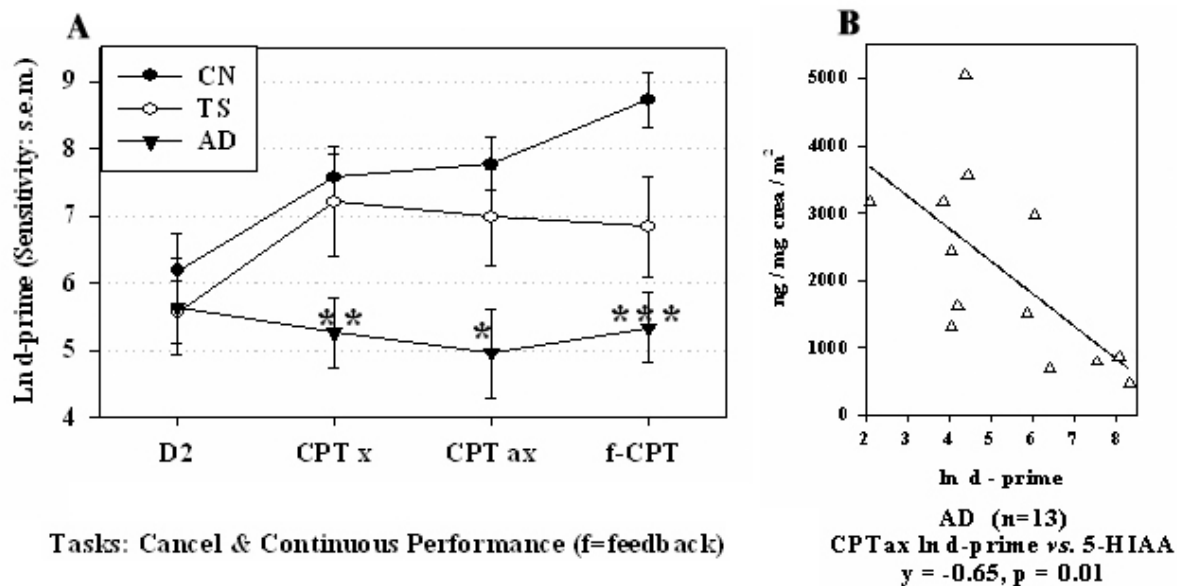

**Figure 4:** **A.** Perceptual sensitivity (ln d-prime) for healthy children (CN) and those with ADHD (AD) or complex tics/Tourette syndrome (TS) on 4 tests of sustained attention: D2 cancellation, continuous performance task (CPTx, CPTax and fCPTax with feedback). Ln d-prime remains specifically and consistently lower on CPT tests in children with ADHD. **B.** Urinary 5-HIAA levels decline as perceptual sensitivity (ln d-prime) in the CPTax task increases in children with ADHD. (Modified after [79] and reproduced with the permission of Elsevier.)

low probability of withholding a prepotent response on the Stop-Task<sup>5</sup>. Indeed this experimental measure of impulsivity correlated with ratings of distractibility and impulsivity.

The association of 5-HT with 'behavioural impulsivity' is reminiscent of an older report that CBCL measures of externalizing behaviour, hostility and aggression in impulsive children and adolescents were inversely related to measures of platelet binding of imipramine [115]. More recently, using the same platelet 5-HT-uptake model in a small group of 14 boys with conduct disorder Stadler and colleagues [116] reported negative correlations for Vmax with ratings of aggression. The interest here lies with the high frequency of comorbidity for ADHD with conduct and oppositional disorders. Indeed in two

small groups of oppositional children with and without ADHD low circulating levels of 5-HIAA were reported [117]. These results confirm the association of low 5-HT activity with the expression of hostility in ADHD and related externalising disorders – a feature that has received more attention in other studies of aggression. But can the findings on cognitive impulsivity be extended?

A series of studies on youngsters with ADHD by Rubia and colleagues is relevant. Comparing the same subjects on Go/no-go and stop-tasks [118], they found not only that errors of commission and difficulties to withhold response (respectively) were related – as one would expect for measures reflecting cognitive impulsivity - but they correlated with other types of errors made (e.g. omission, anticipation), reminiscent of an attentional impairment. Neuroimaging showed that that the ADHD cases did not show the increase of activation in the right medial and inferior frontal gyri seen in the

<sup>5</sup> Rather than reflecting a pure motor problem, Kenemans and colleagues have shown that a disturbance of attention-related processing contributes to impaired stopping on the stop-signal task in adults with ADHD [114].

healthy controls. It happened to be in these regions that tryptophan depletion in healthy young adults also blocked activation during performance of a Go/no-go-flanker task [86: cf. fig. 3]. But, to interpret this in terms of 5-HT activity one must be very careful in deducing the likely effects that a rapid depletion of tryptophan has on the 5-HT system. Acute reduction actually decreases the availability of 5-HT<sub>2a</sub> binding sites in these and related frontal regions: this is in contrast to what is seen for impulsive aggression (see start of this section) and what occurs after chronic tryptophan reduction [119]. While in the animal model 5-HT<sub>1a</sub> binding following tryptophan depletion may only decrease in the dorsal raphe where it plays a presynaptic role: indeed even this change has been reported to disappear with time [120]. So it would be plausible to interpret Rubia's results as supportive of 5-HT function proposed here to explain cognitive rather than behavioural impulsivity.

The role of 5-HT in impulsivity has received considerable attention in the rodent model. In a 5-choice serial reaction time task with 5 seconds between trials, premature responding provides a useful measure of impulsivity. Using microdialysis and postmortem analyses Dalley and colleagues [121] found impulsivity to relate to 5-HT release, especially in prefrontal regions. In apparent contrast a chemical lesion depleting 5-HT levels resulted in premature responses on a simple visual task but did not influence impulsive choice in rats [122] or other higher cognitive functions such as shifting attentional set in Marmosets [123]. However it is perhaps fundamentally difficult to draw a clear distinction in animal work between situations testing for the ability to withhold a prepotent

response and cognitive decisions that are made too rapidly. Such distinctions are made even more difficult by this model being suitable for examining delayed discounting.

The ability to withhold response for an immediate small reward in favour of a delayed but larger one has been described as delayed discounting or delayed gratification. When offered such choices ADHD children are widely described as even less capable of waiting than healthy young children [124]. Such "impulsivity" in animals is associated with 5-HT depletion, treatment with the 5-HT<sub>1a</sub> agonist 8OH-DPAT or increased frontal 5-HT release without changes in metabolite levels [125-127]. Such data would seem to imply that impulsivity in this paradigm appears similar to the behavioural (motor) impulsivity described at the start of this section. But a close reading of my brief presentation shows that I have grouped data from systemic and local treatments and measures. A translation of these to the two categories of impulsivity described above and to the situation in ADHD must differentiate potentially opposite alterations of 5-HT activity in different brain regions with different results, as described by Rubia et al. [86] above. For further comparisons and contrasts of the effects of brain lesions and drug treatments the reader should consult the review of Kalenscher [128].

#### **Genetic studies:**

To date studies of the potential genetic involvement in the ADHD syndrome have concerned some 6 of the 22 or more 5-HT receptors, the 5-HT transporter (5HTT), the enzyme for 5-HT synthesis in the CNS (tryptophan hydroxylase, TPH2) and for 5-HT breakdown (monoamine oxidase, MAO). Fifteen years ago the heritability of 5-HT metabolism was demonstrated in primates [129] and then low levels of 5-

HIAA were related to a TPH genotype in the sons of violent (impulsive) offenders [130]. Only in this decade has evidence crystallised to support an association between 5-HT gene activity and ADHD [131].

#### ***Serotonin-1 Receptors:***

In the 5-HT1 family of receptors behavioural interests have focussed on the 5-HT1a site where agonists have been reported from different laboratories, somewhat confusingly, to be capable of increasing and decreasing measures of impulsivity [132]. But geneticists have focussed on the 5-HT1b site where activation has been associated with motor activity, exploration, aggression and vulnerability to substance abuse [review 133]. The reason for this focus probably lies with the early description of increased aggression [134] and even impaired attention-related sensory gating in 5-HT1b knockout mice [135]. However, more recently 5-HT1B activation has been associated with the perceived intensity of rewarding and aversive cues (in this case, cocaine sensitivity) in the mesolimbic system of rodents [136]. Such a role not only conforms to the 5-HT function in modulating gain in information transfer (see above) but is relevant to the integration of influences on delayed gratification, described as being out of balance in ADHD in the last section.

The 5-HT1b receptor gene maps to 6q12/13. Based on 273 nuclear families Hawi et al. [137] first reported preferential transmission in ADHD for a particular allele (861G) for this receptor. At a trend level this was confirmed [138], and a site mapping close by to the 5-HT1b locus also suggested linkage [lod score 3.3, 139]. This result was refined by Smoller et al. [140] who reported paternal over-transmission of the G861 allele that was especially evident in cases with the

inattentive ADHD subtype. This specificity may explain the negative finding reported by other groups concentrating on the combined subtype of ADHD [141-143].

The only other gene in this receptor family that has been part of an ADHD investigation is that for 5-HT1E. Remarkably little is known about this receptor, but it seems to be fairly widely distributed in the brain at low densities, with more marked levels in the subiculum and entorhinal cortex. In the frontal cortex, in contrast to 5-HT1a sites that are prominently found in layer II and the deep layers, the 5-HT1E site is fairly homogeneously distributed across all layers [144]. A recent study of over a 1000 polymorphisms spanning 51 candidate genes, found that one for 5-HT1E was among 18 that obtained nominal significance [92]. Hence, it would be worthwhile to make a more specific study including this marker.

#### ***Serotonin-2 Receptors:***

The 5-HT2a receptor gene maps to 13q14-21. There was an early report of linkage disequilibrium based on 115 families and 143 cases of ADHD [145]. The authors described preferential transmission of the 452Tyr allele (but not the T102C polymorphism) to affected offspring. But using a variety of analysis methods, this result has not been confirmed since then [137, 141, 142, 146, 147]. However, there is an indication that these alleles should still be included in future studies. For example, returning to the T102 polymorphism, Su et al. [148] reported that the T allele was twice as frequent and the C allele was far less frequently transmitted in their case-control study. The authors tentatively suggested that the former could be a risk factor while the latter may have a protective function.

Among the many caveats and criticisms that may be directed at these limited studies is the question of which subgroup was examined and at what age. Most studies, as yet, were based on samples with a mixture of ADHD subtypes and other comorbidities in patients covering a wide age range. Thus, Reuter et al. [149] found that the C-allele of the 5-HT<sub>2a</sub> receptor was significantly associated with ratings of hyperactivity and impulsivity. This provides an intriguing contrast to the 5-HT<sub>1b</sub> association with inattentivity described above. Further, considering the age-dependent increase of 5-HT activity across the typical age-range studied, it is of interest that the -1438A>G polymorphism was found to be associated with remission status, particularly a functional remission that one might expect among older subjects [150].

Work has hardly started on the associations of other members of the 5-HT<sub>2</sub> family of receptors. However a recent study of the relationship between the C-759T & G-697C polymorphisms of HT<sub>2c</sub> & ADHD in 488 Han Chinese families showed that the -759C allele, the -697G allele, & haplotype -759C/-697G were significantly over-transmitted to affected probands, while haplotypes -759C/-697C & -759T/-697C were under-transmitted. Along the lines suggested above as worthwhile exploring, the families were divided into the 3 main diagnostic subtypes. The -697G allele & haplotype -759C/-697G were significantly over transmitted to combined type cases, while haplotype -759T/-697C was under-transmitted to these individuals. No biased transmission of any allele or haplotype was observed for cases belonging to the inattentive subtype [151]. Further study of the transmission of polymorphisms influencing 5-HT<sub>2c</sub> receptor are of interest because it is as much involved as the 5-HT<sub>2a</sub> site in interacting with the DA system. Activation

of 5-HT<sub>2c</sub> sites can inhibit nigrostriatal and mesolimbic activity [152, 153] and in the rodent model their blockade can lead to increased locomotion [154].

#### ***Other Serotonin Receptors:***

With regard to other 5HT receptors a recent report from the Chinese group is of interest [155]. They described transmission equilibrium and haplotype analyses of a 5-HT<sub>4</sub> polymorphism (that maps to chromosome 5q32) in 326 family trios containing 41% combined and 53% inattentive ADHD subtypes. There was indeed a tendency for the T allele of the 83097 C> T polymorphism of HTR<sub>4</sub> to be preferentially transmitted to ADHD children. However, it is not clear whether or not one or the other subtype made a larger contribution to this result. This is important for an interpretation as the inattentive group was disproportionately represented with respect to its normal prevalence. Further, the authors do not discuss the potential role of the comorbidity found in three quarters of their sample. Nevertheless, the result is of interest as in animal studies 5-HT<sub>4</sub> activation exerts a facilitatory (gain-like) control in cortical and limbic regions [156], where knockout animals are impaired in novelty-seeking and some cognitive functions [157]. However, considering the high concentrations of binding sites also found in the basal ganglia [158], a full understanding of the role of this site should take the apparently inhibitory interactions with nigral DA into account [159]. Nonetheless from a genetic point of view the potential role of 5-HT<sub>4</sub> sites may be contrasted with the absence of effects reported for 5-HT<sub>5a</sub> and 5-HT<sub>6</sub> involvement in transmission in ADHD [160].

#### ***Tryptophan Hydroxylase:***

TPH<sub>2</sub> encodes the rate limiting enzyme for the synthesis of 5-HT in the brain. It

maps to the chromosome 12q21.1. (This form of the enzyme differs from that of TPH1 found in the gut, pineal, spleen and thymus.) Clearly the efficiency of the form of enzyme present will influence the supply and availability of neurotransmitter. Some 8 single nucleotide polymorphisms have been investigated in many hundreds of cases of ADHD by 4 research groups using different methods. While each study reports preferential transmission for one or two of these polymorphisms, each laboratory has only been able to partially replicate the results from the others [90-93, 161]. This implies similarities, but also undetermined differences in the nature of the samples recruited. However, one tends to think that with so much smoke, there must be some fire here. (The interested reader should seek the methodological details in the original papers.)

However, only one study [93] has related transmission to a functional phenotype. The 344 patients performed a CPT (the TOVA). The study describes associations of the polymorphisms transmitted with the accuracy of the children's performance (errors of omission) and with the putative endophenotype of reaction time variability. Intriguingly there was no association with the more impulsive feature of errors of commission. This result fits the more general picture that in adults' 5-HT synthesis activity (TPH2) is reflected in the executive control of attention [162]. However, in addition, this latter study did indeed find a relationship with cognitive impulsivity. Overall while there are signs that some feature(s) of 5-HT synthesis would seem to relate to an aspect of behavioural control expressed in ADHD, it is impossible as yet to be more precise about either of the sets of features involved.

### ***Serotonin Uptake:***

The 5HTT gene maps to 17q11.1-12. Several alleles lying close to this locus or reflecting 5HTT binding activity have been investigated, but the majority of studies refer to shorter vs. longer polymorphisms for the 5HTT promoter (5-HTTLPR). Homozygotes for the short form (s/s) show enhanced CNS responsivity or sensitivity with respect to those with the long form. On the one hand the short form shows reduced transcriptional efficiency that implies less 5-HT uptake, and perhaps fewer binding sites. On the other hand more 5-HT in the synapse will (arguably) bring about more neurotransmission in the long run. Homozygotes for the long form (l/l) may have fewer binding sites, but should – within obvious limits – be able to exert better control over synaptic transmission: beyond these limits function could be slow or inefficient. Abundant studies have linked carriers of the short allele to stress sensitivity and anxiety. However, Canli and colleagues [163] elegantly showed that this derived more from a decreased responsivity to neutral stimuli rather than an increased sensitivity to negative stimuli. This differentiated view implies that it is not easy to propose that it is better to have one or the other genotype, let alone predict if the one predominates in ADHD.

The results of studies with ADHD so far indeed suggest that a more detailed specification of subtype, comorbidity and stratification is necessary. To a greater or lesser degree with various methods it first seemed that the l/l (perhaps also the l/s) genotype was preferentially transmitted in youngsters with ADHD compared to those without the disorder [164-166]. However, Langley and colleagues [167] failed to replicate this in a case-control and family-based study. Then Seeger et al.

[168] found that when the I/I genotype was associated with the 7-repeat DA D4 polymorphism, response to treatment left much to be desired. In addition they also found that comorbid conduct disorder was an important moderator [169]. Negative results also came later from Germany [142]. A Canadian group, Wigg et al. [170], looked at a number of alleles of the functional polymorphism in the promoter of 249 children with ADHD (62% combined type) in a clinical sample. They found no evidence for an association of these polymorphisms, or haplotypes of these polymorphisms, to ADHD at all. This makes the report from Curran and colleagues [67] in London the more striking. They reported a highly significant association with the long allele of the 5-HTTLPR, as well as with 5 other single nucleotide polymorphisms. But in contrast to the Canadian work this was a population based analysis using composite symptom-ratings, albeit with a similar number of probands. In contrasting these results I have here deliberately implicated possible reasons for the very different findings. How much the more carefully should one then treat the recent report from a Han Chinese sample. In China, it would seem that it is the short allele that is preferentially transmitted in ADHD [68]. Nonetheless, to show also how uncertain the ground yet is for interpreting these results, one notes that Heiser et al [142] with a European sample also saw a slight trend in the same direction.

#### ***Catabolism and Monoamine Oxidase:***

The amount of 5-HT in and around the synapse will in part depend on how rapidly it is metabolised. Monoamine oxidase-A (MAO-A) is the main enzyme responsible. Its gene is located on the X-chromosome (Xp11.23-Xp11.4) where it overlaps to a large extent with the gene for MAO-B. As one would expect from the

discussion above, associations for behavioural or aggressive impulsivity with lower MAO activity have been reported from several different population samples [e.g. 171, 172]. A number of polymorphisms for MAO-A have been examined, especially those in the promoter region that contains shorter (2-3) and longer repeat sequences (4-5). In particular the shorter alleles that give rise to low enzyme activity have attracted attention.

Associations with shorter alleles of the promoter VNTR have been replicated [173, 174] and attributed to maternal transmission [175]. Considering the behavioural association of this allele it is not too surprising that another group emphasized the finding for ADHD children with comorbid conduct disorder [176]. Despite one negative finding [177] it is the association with the externalizing aspects of behaviour that is receiving some acceptance [178]. However, a second genetic variant (the G941T allele, [174]) or the nearby region [92, 179] may also be associated with ADHD. But intriguingly this variant results in the transcription of an *active* form of the enzyme. Should these reports receive further support then the possibility of transmission of the active long allele for the promoter [180] must be seriously entertained.

The possibility that both high and low activity forms can be preferentially transmitted in ADHD could reflect divergent aetiologies for the samples selected. Thus, on the one hand the long allele has been reported to be associated with Tourette syndrome [181], a condition that is frequently comorbid with ADHD. On the other hand the low activity form may predominate in the context of maltreated children reported to show aggression and conduct problems [182].



A different interpretation would reflect the nature of the impulsivity recorded, as discussed earlier in this article. The long allele (and increased enzyme activity) has also been associated with impulsive personality traits [183]. The potential connection with 'cognitive impulsivity' has been provided in a recent fMRI investigation using a Go/no-go task [184]. In brief this remarkable study noted that activation of the ventrolateral prefrontal cortex was higher in the carriers of the high activity allele. It may be noted that this part of the brain is well-known through the disinhibition that damage can cause, and for the high level of 5-HT innervation it receives. In the fMRI study, ratings of impulsivity were positively related to the activation recorded there in carriers of the high activity allele, but negatively related in the carriers of the low activity allele.

Whether the genetic contribution of MAO variants to ADHD reflects the subtype of ADHD and the etiology thereof, or rather an improved definition of the nature of impulsivity recorded (or both), it seems likely that genetically influenced variants of MAO-A are likely to be relevant to the expression of ADHD.

In summary, there is strong reason based on these genetics' studies to believe that 5-HT activity is both distinguishable from normal in the ADHD population and that it contributes to the cognitive processing style expressed in those with ADHD. This style is both attention-related and shows features of impulsivity. Studies of 5-HT synthesis, of receptors found pre- and post-synaptically, as well as those influencing uptake all appear to be influenced by polymorphisms preferentially transmitted to ADHD cases. The frustration is that the heterogeneity of results arising from different methods and unrefined sample

selection still hinder a clearer level of identification of the nature of the function affected.

#### **Expert commentary and Five-year view:**

Research into the monoamine involvement in ADHD went through a phase of measuring peripheral metabolites of the neurotransmitters and looking for associations with the syndrome long ago. This may have helped tune the evolution of our ideas about the disorder, but in the long term it was not a hugely successful enterprise. Genetics' studies appear to be going through a similar phase of evolution.

The studies reviewed above moved on to study domains of function and dysfunction. This has been particularly useful for distinguishing the different roles of 5-HT in behavioural and cognitive impulsivity: such work is likely to be extended in the field of neuroimaging. This work will also need to be firmly based on the development of our understanding of the interactions of 5-HT with the other biogenic amines [review 185]. But it can also be seen that genetic studies are gradually starting to follow a similar course (including the study of interactions between genetic loci). This has started with the sub-grouping of patients by diagnosis and comorbidities. On the present evidence we can expect big differences if the youngsters also have conduct disorder, tic syndrome or reading disabilities. This will become evident when technological advances permit a screen for half a million polymorphisms as 'the order of the day' rather than today's exception. This must of course be accompanied by leaps of progress in the statistical methods applied. Here, there may be some delays, but there are encouraging trends already evident (e.g. methods of family based association testing).

However, it seems extraordinary that there are two fields of 5-HT function that I have not been able to cover, as there are virtually no data directly relevant to ADHD. These will surely gain attention in the coming years.

The first concerns 5-HT as a growth or trophic factor especially in the prenatal period when gene and environment interactions may be so strong. Maternal 5-HT – so abundant in the placenta – is involved in morphogenesis in the foetal CNS before the appearance of 5-HT neurons [12]. 5-HT signals modulate axonal responsiveness to the classical guidance cues in the development of neural pathways [186]. From primate work it's known that parenting style – that itself depends on the status of the maternal 5-HT system – can influence the extent of development and responsiveness of the offspring's 5-HT system [187]. More crudely prenatal exposure to agents that influence 5-HT strongly, like nicotine [188] or alcohol [189], alter the balance of expression of different 5-HT receptors. Smoking and drinking are well known as potential risk factors for the development of some types of ADHD [190, 191]. It seems likely that problems with trophic 5-HT can influence features that are later associated with ADHD, but relevant studies are still in the planning stage.

The second field concerns the control by 5-HT of glial functions in providing energy to rapidly firing neurons and in the development of myelinated axons [192]. The energy flow to neurons (lactate shuttle) can be influenced by 5-HT<sub>1a</sub> blockade / stimulation [193]. Indeed cultured astrocytes express mRNA for five 5-HT<sub>1</sub>, three 5-HT<sub>2</sub>, and the 5-HT<sub>5b</sub>, 5-HT<sub>6</sub> and 5-HT<sub>7</sub> receptors [194]. We should soon find out if and how these binding sites influence the known facilitation of energy supplies by the catecholamines

and methylphenidate [192,195] and provide a fuller account of how this drug exerts its beneficial effects. The neurotrophic and glial functions of 5-HT may indeed be related. The neurotrophic function is claimed to be mediated by 5-HT<sub>1a</sub> binding sites, the stimulation of which releases the cytokine S100B [196]. To a large extent this cytokine is a marker for the integrity of astrocytes with neuroprotective function [197]. The potential of this 5-HT-cytokine link for new targets for pharmacological intervention is illustrated by the report that stimulation of this link can reduce the neurotoxic effects of alcohol in animals [198]. After 5 years a better understanding of the bases for these interactions and for potential therapeutic intervention should be available.

#### **Key Issues**

- Crude peripheral measures or drug/hormone challenge studies as a general reflection of the activity of 5-HT systems are correlated better with functional domains rather than diagnosis.
- Relating structure to function in animal model studies, despite the widespread projections of 5-HT neural systems, is aided by differential distributions of histological neuron types and of numerous pre- and postsynaptic receptors.
- A role for 5-HT in dysfunctional domains in ADHD increases as one considers, motor, attentional and impulsivity-control systems, in turn.
- In exogenous attentional processing perceptual sensitivity is disturbed by overactive 5-HT systems, while endogenous selective processes, as in switching set, are sensitive to the role of 5-HT in the 'volume-control' of information processing.

- It is useful to consider impulsivity, common in those with ADHD, as two separate domains: behavioural and cognitive impulsivity. These reflect relatively low and relatively high 5-HT activity, respectively. In turn these levels of activity will reflect partly the comorbidity of more or fewer externalizing symptoms, respectively.

- There is tentative evidence for transmission of an allele associated with 5-HT<sub>1b</sub> activity more in ADHD patients with inattentive features, while there are indications that an allele associated with receptors from the 5-HT<sub>2</sub> family (5-HT<sub>a/c</sub>) may be preferentially transmitted to those showing hyperactivity/impulsivity.

- Preliminary evidence suggests that genetic influences on the synthesis (affecting release into the synapse) and on uptake of 5-HT from the synapse moderate 5-HT activity in patients with ADHD. But the direction and nature of the influence remains unclear as a result of apparent problems of stratification (developmental age, race and socio-economic features).

- Relatively neglected fields of 5-HT study concern its non-transmitter, support functions in development (neurotrophic role) and rapid neural firing (astrocytic energy supply to the synapse) needed to maintain ongoing responses.

- Evidence is accumulating for roles of altered 5-HT activity in different features of ADHD. These features are expressed to varying degrees in different patients. Explanations of the expression of these changes should take into account the status of other monoamine systems, especially that of the DA system.

## References:

Papers of special note have been highlighted as: \* of interest

\*\* of considerable interest

1. Banaschewski T, Coghill DR, Santosh PJ *et al.* Long-acting medications for the hyperkinetic disorders: A systematic review and European treatment guidelines. *Eur. Child Adolesc. Psychiat.* 15, 476-495 (2006).

2. Asherson P. Clinical assessment and treatment of attention deficit hyperactivity disorder in adults. *Expert Rev. Neurotherapeutics* 5, 525-539 (2005).

3. Committee of Children with Disabilities and Committee on Drugs. Medication for children with attentional disorders. *Pediatrics* 98, 301-304 (1996).

4. Jensen PS, Arnold LE. National Institute of Mental Health Multimodal Treatment Study of ADHD follow-up: 24-month outcomes of treatment strategies for attention-deficit / hyperactivity disorder. *Pediatrics* 113, 754-761 (2004).

5. Oades RD. Attention deficit disorder with hyperactivity (ADDH): the contribution of catecholaminergic activity. *Prog. Neurobiol.* 29, 365-391.(1987)

6. Zametkin AJ, Rapoport JL. Neurobiology of attention deficit disorder with hyperactivity. *J. Am. Acad. Child Adolesc. Psychiat.* 26, 676-686, (1987).

7. Steinbusch HWM. Distribution of serotonin immunoreactivity in the central nervous system of the rat: cell bodies and terminals. *Neurosci.* 6, 557-618, (1981).

8. Eastwood SL, Burnet PW, Gittins W *et al.* Expression of serotonin 5-HT<sub>2A</sub> receptors in the human cerebellum and alterations in schizophrenia. *Synapse* 42, 104-114, 2001.

9. Sari Y. Serotonin<sub>1B</sub> receptors: from protein to physiological function and

behavior. *Neurosci. Biobehav. Rev.* 28, 565-582, (2004).

10. Jacobs BL, Fornal CA. Serotonin and Behavior: a General Hypothesis. In: *Psychopharmacology: The Fourth Generation of Progress*, Bloom FE, Kupfer DJ (Eds.), Raven Press, NY, 461-469, (1995).

11. Karadottir R, Attwell D. Neurotransmitter receptors in the life and death of oligodendrocytes. *Neurosci.* 145, 1426-1438, (2007).

12. Cote F, Fligny C, Bayard E, *et al.* Maternal serotonin is crucial for murine embryonic development. *Proc. Natl. Acad. Sci. (USA)* 104, 329-334, (2007).

13. Tork I. Anatomy of the serotonergic system. *Ann. NY Acad. Sci.* 600, 9-34, (1990).

\* This is a classical summary description of the anatomy and projections of 5-HT systems in the CNS

14. Jacobs BL, Azmitia EC. Structure and function of the brain serotonin system. *Physiol. Rev.* 72, 165-229 (1992).

\* A benchmark review of the 5-HT system.

15. Kosofsky BE, Molliver ME. The serotonergic innervation of the cerebral cortex: different classes of axon terminals arise from the dorsal and median raphe nuclei. *Synapse*, 1, 153-168 (1987).

16. Soghomonian J-J, Descarries L, Watkins KC. Serotonin innervation in adult rat neostriatum. II. Ultrastructural features: a radioautographic and immunocytochemical study. *Brain Res.* 481, 67-86, (1989).

17. Oades RD. The Roles of Norepinephrine and Serotonin in ADHD. In: *Attention Deficit Hyperactivity Disorder: From Genes to Animal Models to Patients*, Gozal D, Molfese DL (Eds.), Humana Press, Tootawa, NY, 97-130, (2005).

\*\* An extensive, multidisciplinary view of function and dysfunction in the developing CNS, and on potential differential contributions to features of ADHD.

18. Coleman M. Serotonin concentrations in whole blood of hyperactive children. *J. Pediatr.* 78, 985-990, (1971).

19. Saul RC, Ashby CD. Measurement of whole blood serotonin as a guide in prescribing psychostimulant medication for children with attentional deficits. *Clin. Neuropharmacol.* 9, 189-195, (1986)

20. Ferguson HB, Pappas BA, Trites RL, *et al.* Plasma free and total tryptophan, blood serotonin, and the hyperactivity syndrome: no evidence for the serotonin deficiency hypothesis. *Biol. Psychiatry* 16, 231-238 (1981).

21. Bhagnan HN, Coleman M, Coursina DB. The effect of pyridoxine hydrochloride on blood serotonin and pyridoxal phosphate contents in hyperactive children. *Pediatrics* 55, 437-441 (1975).

22. Spivak B, Vered Y, Yoran-Hegesh R, Averbuch E, Mester R, Graf E. Circulatory levels of catecholamines, serotonin and lipids in attention deficit hyperactivity disorder. *Acta Psychiatr. Scand.* 99, 300-304, (1999).

23. Irwin M, Belendink K, McCloskey K, Freedman DX. Tryptophan metabolism in children with attention deficit disorder. *Am. J. Psychiat.* 138, 1082-1085 (1981).

24. Shetty T, Chase TN. Central monoamines and hyperkinesis of childhood. *Neurol.* 26, 1000-1002, (1976).

25. Castellanos FX, Elia J, Kruesi MJ, *et al.* Cerebrospinal fluid monoamine metabolites in boys with attention-deficit hyperactivity disorder. *Psychiatry Res.* 52, 305-316, 1994.

26. Rapoport JL, Quinn PO, Scribanic N, Murphy DL. Platelet serotonin of

hyperactive school age boys. *Br. J. Psychiatry* 125, 138-140, (1974).

27. Kusaga A, Yamashita Y, Koeda T *et al.* Increased urine phenylethylamine after methylphenidate treatment in children with ADHD. *Ann. Neurol.* 52, 371-374 (2002).

28. Oades RD, Müller BW. The development of conditioned blocking and monoamine metabolism in children with attention-deficit-hyperactivity disorder or complex tics and healthy controls: an exploratory analysis. *Behav. Brain Res.* 88, 95-102, (1997).

29. Oades RD, Daniels R, Rascher W. Plasma neuropeptide Y levels, monoamine metabolism, electrolyte excretion and drinking behavior in children with attention-deficit hyperactivity disorder (ADHD). *Psychiatry Res.* 80, 177-186, (1998).

30. Oades RD, Röpcke B, Schepker R. A test of conditioned blocking and its development in childhood and adolescence: relationship to personality and monoamine metabolism. *Dev. Neuropsychol.* 12, 207-230, (1996).

31. Oades RD. Dopamine may be 'hyper' with respect to noradrenaline metabolism, but 'hypo' with respect to serotonin metabolism in children with ADHD. *Behav. Brain Res.* 130, 97-101, (2002).

\* A short summary of evidence 5 years ago for the level of dopamine activity "relative" to that of noradrenalin and serotonin.

32. O'Neill MF, Heron-Maxwell CL, Shaw G. 5-HT<sub>2</sub> receptor antagonism reduces hyperactivity induced by amphetamine, cocaine and MK-801 but not D-1 agonist c-APB. *Pharmacol. Biochem. Behav.* 63, 237-244, (1999).

33. Barr AM, Lehmann-Masten V, Paulus M *et al.* The Selective Serotonin-2A

Receptor Antagonist M100907 Reverses Behavioral Deficits in Dopamine Transporter Knockout Mice. *Neuropsychopharmacol.* 29, 221-228, (2004).

34. Su, Y-A.; Si, T-M.; Zhou, D-F *et al.* Risperidone attenuates MK-801-induced hyperlocomotion in mice via the blockade of serotonin 5-HT<sub>2A/2C</sub> receptors. *Eur. J. Pharmacol.* 564, 123-130, (2007).

35. Hughes ZA, Starr KR, Scott CM *et al.* Simultaneous blockade of 5-HT<sub>1A/B</sub> receptors and 5-HT transporters results in acute increases in extracellular 5-HT in both rats and guinea pigs: in vivo characterization of the novel 5-HT<sub>1A/B</sub> receptor antagonist/5-HT transport inhibitor SB-649915-B. *Psychopharmacol.* 192, 121-133, (2007).

36. Pollier F, Sarre S, Aguerre S *et al.* Serotonin reuptake inhibition by citalopram in rat strains differing for their emotionality. *Neuropsychopharmacol.* 22, 64-76, (2000).

37. Durand, M.; Berton, O.; Aguerre, S. Effects of repeated fluoxetine on anxiety-related behaviours, central serotonin systems and the corticotropic axis in SHR and WKY rats. *Neuropharmacol.* 38, 893-907, (1999).

38. Stocker SD, Muldoon MF, Sved AF. Blunted fenfluramine-evoked prolactin secretion in hypertensive rats. *Hypertension* 42, 719-724, (2003).

39. De Villiers AS, Russell VA, Sagvolden T *et al.*  $\alpha$ 2-adrenoceptor mediated inhibition of [<sup>3</sup>H]dopamine release from nucleus accumbens slices and monoamine levels in a rat model for attention-deficit hyperactivity disorder. *Neurochem. Res.* 20, 427-433, (1995).

40. Boix F, Qiao S-W, Kolpus T *et al.* Chronic MAO-B inhibition does not affect behaviour in an animal model of attention

deficit disorder. *Eur. J. Neurosci. Suppl.* 8, 172, (1995).

41. Hoffmann P, Elam M, Thoren P *et al.* Effects of long-lasting voluntary running on the cerebral levels of dopamine, serotonin and their metabolites in the spontaneously hypertensive rat. *Life Sci.* 54, 855-861, (1994).

42. Gauffre J-C, Aquerre S, Mormede P. *et al.* Cortical [<sup>3</sup>H]ketanserin binding and 5HT<sub>2a</sub> receptor-mediated inositol phosphate production in the spontaneously hypertensive rat and Lewis rat strains. *Neurosci. Lett.* 236, 112-116, (1997).

43. Berton O, Aguerre S, Sarrieau A *et al.* Differential effects of social stress on central serotonergic activity and emotional reactivity in Lewis and spontaneously hypertensive rats. *Neurosci.* 82, 147-159, (1997).

44. Russell VA, Lam D, Sagvolden T *et al.* Monoaminergic aspects of animal models of-ADHD. In *Attention-Deficit/Hyperactivity Disorder and the Hyperkinetic Syndrome: Current Ideas and Ways Forward*. Oades RD (Ed), Nova Science Publishing Inc., Hauppauge, New York, 77-108, (2006).

\*\* A major review of neurobiological work with animal models, especially the SHR, emphasizing the contributions of dopamine and noradrenalin.

45. Dev BR, Philip L. Extracellular catechol and indole turnover in the nucleus of the solitary tract of spontaneously hypertensive and Wistar-Kyoto normotensive rats in response to drug-induced changes in arterial blood pressure. *Brain Res. Bull.* 40, 111-116, (1996).

46. Tsukamoto K, Sved AF, Ito S *et al.* Enhanced serotonin-mediated responses in the nucleus tractus solitarius of

spontaneously hypertensive rats. *Brain Res.* 863, 1-8 (2000).

47. Mehlman PT, Westergaard G.C, Hoos BJ. *et al.* CSF 5-HIAA and night-time activity in free-ranging primates. *Neuropsychopharmacol.* 22, 210-218, (2000).

48. Castellanos FX, Elia J, Kruesi MJP *et al.* Cerebrospinal fluid homovanillic acid predicts behavioral response to stimulants in 45 boys with attention deficit/hyperactivity disorder. *Neuropsychopharmacol.* 14, 125-137, (1996).

49. Gadow KD. Pediatric psychopharmacology: a review of recent research. *J. Child Psychol. Psychiatry.* 33, 153-195, (1992).

50. Malhotra S, Santosh PJ. An open clinical trial of buspirone in children with attention-deficit/hyperactivity disorder. *J. Am. Acad. Child Adolesc. Psychiatry.* 37, 364-371, (1998).

51. Clarke AR, Barry RJ, McCarthy R *et al.* EEG predictors of good response to Imipramine Hydrochloride in children with Attention Deficit/Hyperactivity Disorder. In *Attention-Deficit/Hyperactivity Disorder and the Hyperkinetic Syndrome: Current Ideas and Ways Forward*. Oades RD (Ed), Nova Science Publishing Inc., Hauppauge, New York, 77-108, (2006).

52. Leonard BE, McCartan D, White J *et al.* Methylphenidate: a review of its neuropharmacological, neuropsychological and adverse clinical effects. *Hum. Psychopharmacol. Clin. Exp.* 19, 151-180, (2004).

\* A very useful summary of the physiological and psychological effects of the most widely used medication for ADHD

53. Treisman AM. Strategies and models of selective attention. *Psychol. Rev.* 76, 282-299, (1969).

54. Shiffrin RM, Schneider W. Controlled and automatic human

information processing: II. Perceptual learning, automatic attending and a general theory. *Psychol. Rev.* 84, 127-190, (1977).

55. Posner MI, Snyder CRR. Facilitation and inhibition in the processing of signals. In: *Attention and Performance, V*, Rabbitt PM, Dornic S. (Eds.), Academic Press, London, New York, 669-681, (1975).

56. Neisser U. *Cognitive Psychology*. Appleton-Century-Croft, New York, (1967).

57. Posner MI, Petersen SE. The attention system of the human brain. *Ann. Rev. Neurosci.* 13, 25-42, (1990).

58. Jacobs BL, Fornal CA, Wilkinson LO. Neurophysiological and neurochemical studies of brain serotonergic neurons in behaving animals. *Ann. NY Acad. Sci.* 600, 260-271, (1990).

59. Oades RD. The role of noradrenaline in tuning and dopamine in switching between signals in the CNS. *Neurosci. Biobehav. Rev.* 9, 261-283, (1985).

60. Posner M.I, Rothbart MK, Sheese BE. Attention genes. *Dev. Sci.* 10, 24-29, (2007).

61. Hurley LM, Pollak GD. Serotonin differentially modulates responses to tones and frequency-modulated sweeps in the inferior colliculus. *J. Neurosci.* 19, 8071-8082, (1999).

62. Hegerl U, Juckel G. Auditory evoked dipole source activity: indicator of central serotonergic dysfunction in psychiatric patients? *Pharmacopsychiat.* 27, 75-78, (1994).

63. Pfefferbaum A, Roth WT, Ford JM. Event-related potentials in the study of psychiatric disorders. *Arch. Gen. Psychiatry* 52, 559-564, (1995).

64. Oades RD. Connections between

studies of the neurobiology of attention, psychotic processes and event-related potentials. *Electroencephalogr. Clin. Neurophysiol. Suppl.* 44, 428-438.

65. Hegerl U, Juckel G. Intensity dependence of auditory evoked potentials as an indicator of central serotonergic neurotransmission: a new hypothesis. *Biol. Psychiat.* 33, 173-187, (1993).

66. Gallinat J, Senkowski D, Wernicke C *et al.* Allelic variants of the functional promoter polymorphism of the human serotonin transporter gene is associated with auditory cortical stimulus processing. *Neuropsychopharmacol.* 28, 530-532, (2003).

67. Curran S, Purcell S, Craig I *et al.* The serotonin transporter gene as a QTL for ADHD. *Am. J. Med. Genet.* 134B, 42-47, (2005).

\* Demonstration of unusually clear QTL genetic associations between some markers of 5-HT activity and ADHD-like symptoms in the general population.

68. Li J, Wang Y, Zhou R *et al.* Association between polymorphisms in serotonin transporter gene and attention deficit hyperactivity disorder in Chinese Han subjects. *Am. J. Med. Genet.* 144B, 14-19, (2007).

69. Nathan PJ, Segrave R, Phan KL *et al.* Direct evidence that acutely enhancing serotonin with the selective serotonin reuptake inhibitor citalopram modulates the loudness dependence of the auditory evoked potential (LDAEP) marker of central serotonin function. *Hum. Psychopharmacol. Clin. Exp.* 21, 47-52 (2006).

70. Uhl I, Gorynia I, Gallinat J *et al.* Is the loudness dependence of auditory evoked potentials modulated by the selective serotonin reuptake inhibitor citalopram in healthy subjects? *Hum. Psychopharmacol. Clin. Exp.* 21, 463-471,

(2005).

71. Nathan PJ, O'Neill B, Croft RJ. Is the loudness dependence of the auditory evoked potential a sensitive and selective in vivo marker of central serotonergic function? *Neuropsychopharmacol.* 30, 1584-1585, (2005).

72. Dierks T, Barta S, Demisch L *et al.* Intensity dependence of auditory evoked potentials (AEPs) as biological marker for cerebral serotonin levels: effects of tryptophan depletion in healthy subjects. *Psychopharmacol.* 146, 101-107, (2000).

73. Kähkönen S, Mäkinen V, Jääskeläinen IP *et al.* Serotonergic modulation of mismatch negativity. *Psychiatry Res. (Neuroimaging)* 138, 61-74, (2005).

74. Oades RD, Dittmann-Balcar A, Schepker R *et al.* Auditory event-related potentials and mismatch negativity in healthy children and those with attention-deficit- or Tourette-like symptoms. *Biol. Psychol.* 43, 163-185, (1996).

75. Hegerl U. Event-related potentials and clinical response to serotonin agonists in patients with affective disorders. *Eur. Arch. Psychiat. Clin. Neurosci.* 248 suppl.2, 75, (1998).

76. Satterfield JH, Schell AM, Nicholas T. Preferential processing of attended stimuli in attention-deficit hyperactivity disorder and normal boys. *Psychophysiol.* 31, 1-10, (1994).

77. Johnstone SJ, Barry RJ, Anderson JW. Topographic distribution and developmental time course of auditory event-related potentials in two subtypes of attention-deficit hyperactivity disorder. *Int. J. Psychophysiol.* 42, 73-94, (2001).

78. Sergeant JA, van der Meere JJ. Convergence of approaches in localizing the hyperactivity deficit. In *Advances in clinical child Psychology, vol. 13*, Lahey BB,

Kazdin AE (Eds.), Plenum Press, New York, 207-245, (1990).

79. Oades RD. Differential measures of sustained attention in children with attention-deficit/hyperactivity or tic disorders: relationship to monoamine metabolism. *Psychiatry Res.* 93, 165-178, (2000).

80. Nigg JT. Neuropsychologic theory and findings in attention-deficit/hyperactivity disorder: The state of the field and salient challenges for the coming decade. *Biol. Psychiatry.* 57, 1424-1435, (2005).

\*\* An all-round discussion of the neuropsychology of the domains of function impaired in ADHD and the tasks used to demonstrate the problems.

81. Oades RD, Christiansen H. Cognitive switching processes in young people with attention-deficit / hyperactivity disorder. In submission.

82. Jemel B, Achenbach C, Müller B *et al.*, Mismatch negativity results from bilateral asymmetric dipole sources in the frontal and temporal lobes. *Brain Topogr.* 15, 13-27, (2002).

83. Escera C, Corral M-J, Yago E. An electrophysiological and behavioral investigation of involuntary attention towards auditory frequency, duration and intensity changes. *Cogn. Brain Res.* 14, 325-332, (2002).

84. Smith AB, Taylor EA, Brammer M *et al.* Neural correlates of switching set as measured in fast, event-related functional magnetic resonance imaging. *Hum. Brain Mapp.* 21, 247-256, (2004)

85. Smith AB, Taylor EA, Brammer M *et al.* Task-specific hypoactivation in prefrontal and temporoparietal brain regions during motor inhibition and task switching in medication-naive children and adolescents with attention deficit hyperactivity disorder. *Am. J. Psychiatry*



163, 1044-1051, (2006).

86. Rubia K, Lee F, Cleare AJ *et al.* Tryptophan depletion reduces right inferior prefrontal activation during no-go trials in fast, event-related fMRI. *Psychopharmacol.* 179, 791-803, (2004).

87. Rubia K, Smith AB, Brammer MJ *et al.* Abnormal Brain Activation during Inhibition and Error Detection in Medication-Naive Adolescents with ADHD. *Am. J. Psychiat.* 162, 1067-1075, (2005).

88. Loose R, Kaufmann C, Auer DP *et al.* Human prefrontal and sensory cortical activity during divided attention tasks. *Hum. Brain Mapp.* 18, 249-259, (2003).

89. Häger F, Volz H-P, Gaser C *et al.* Challenging the anterior attentional system with a continuous performance task: a functional magnetic resonance imaging approach. *Eur. Arch. Psychiat. Clin. Neurosci.* 248, 161-170, (1998).

90. Sheehan K, Lowe N, Kirley A *et al.* Tryptophan hydroxylase 2 (TPH2) gene variants associated with ADHD. *Mol. Psychiat.* 10, 944-949, (2005).

91. Walitza S, Renner TJ, Dempfle A *et al.* Transmission disequilibrium of polymorphic variants in the tryptophan hydroxylase-2 gene in attention-deficit/hyperactivity disorder. *Mol. Psychiat.* 10, 1126-1132, (2005).

92. Brookes K-J, Xu X, Chen W *et al.* Analysis of 51 candidate genes in DSM-IV combined subtype attention deficit hyperactivity disorder: association signals in DRD4, DAT1 and 16 other genes. *Mol. Psychiat.* 11, 934-953, (2006).

93. Manor I, Eisenberg J, Meidad S *et al.* Association between tryptophan hydroxylase 2 (TPH2) SNPs, performance on a continuance performance test (T.O.V.A.) and response to methylphenidate in participants with

attention deficit hyperactivity disorder (ADHD). In preparation, 2007

94. Wiersema JR, van der Meere JJ, Roeyers H. ERP correlates of impaired error monitoring in children with ADHD. *J. Neural Transm.* 112, 1417-1430, (2005).

95. Liotti M, Pliszka SR, Perez R *et al.* Abnormal brain activity related to performance monitoring and error detection in children with ADHD. *Cortex* 41, 377-388, (2005).

96. Burgio-Murphy A, Klorman R, Shaywitz SE *et al.* Error-related event-related potentials in children with attention-deficit hyperactivity disorder, oppositional defiant disorder, reading disorder, and math disorder. *Biol. Psychol.* 75, 75-86, (2007)

97. Hajcak G, Simons RF. Error-related brain activity in obsessive-compulsive undergraduates. *Psychiatry Res.* 110, 63-72, (2002).

98. Pailing PE, Segalowitz SJ, Dywan J *et al.* Error negativity and response control. *Psychophysiol.* 39, 198-206, (2002).

99. Parsey RV, Oquendo MA, Simpson NR *et al.* Effects of sex, age, and aggressive traits in man on brain serotonin 5-HT(1A) receptor binding potential measured by PET using [C-11]WAY-100635. *Brain Res.* 954, 173-182, (2002).

100. Carver CS, Miller CJ. Relations of serotonin function to personality: current views and a key methodological issue. *Psychiatry Res.* 144, 1-15, (2005).

101. Coccaro EF, Kavoussi RJ, Sheline YI *et al.* Impulsive aggression in personality disorder correlates with platelet 5-HT<sub>2A</sub> receptor binding. *Neuropsychopharmacol.* 16, 211-216, (1997).

102. Tseng MH, Henderson A, Chow SMK *et al.* Relationship between motor

proficiency, attention, impulse, and activity in children with ADHD. *Dev. Med. Child Neurol.* 46, 381-388, (2004).

103. Hervey AS, Epstein JN, Curry JF. Neuropsychology of adults with attention-deficit/hyperactivity disorder: A meta-analytic review. *Neuropsychology*, 18, 485-503, (2004).

104. Winstanley CA, Eagle DM, Robbins TW. Behavioral models of impulsivity in relation to ADHD: Translation between clinical and preclinical studies. *Clin. Psychol. Rev.* 26, 379-395, (2006).

105. Daruna JH, Barnes PA. A neurodevelopmental view of impulsivity. In *The impulsive client: theory research and treatment*. McCown WG, Johnson JL, Shure MB (eds.), The American Psychological Association, Washington, DC, (1993).

106. Evenden JL. Varieties of impulsivity. *Psychopharmacol.* 146, 348-361, (1999).

107. Faraone SV, Asherson P, IMAGE Consortium. The molecular genetics of attention deficit hyperactivity disorder: A View from the IMAGE Project. *Psychiatric Times* August, 21-23, (2005).

108. Clarke RA, Murphy DL, Constantino JN. Serotonin and externalizing behavior in young children. *Psychiatry Res.* 86, 29-40, (1999).

109. Knott P, Haroutunian V, Beirer L *et al.* Correlations postmortem between ventricular CSF and cortical tissue concentrations of MHPG, 5-HIAA and HVA in Alzheimer's disease. *Biol. Psychiatry* 25, 112 (1989).

110. Stanley M, Träskman-Bendz L, Dorovini-Zis K. Correlations between aminergic metabolites simultaneously obtained from human CSF and brain. *Life Sci.* 37, 1279-1286, (1985).

111. Overtom CCE, Verbaten MN, Kemner C *et al.* Effects of methylphenidate, desipramine and L-DOPA on attention and inhibition in children with attention deficit hyperactivity disorder. *Behav. Brain Res.* 145, 7-15, (2003).

112. Oades RD, Slusarek M, Velling S *et al.* Serotonin platelet-transporter measures in childhood attention-deficit/hyperactivity disorder (ADHD): clinical versus experimental measures of impulsivity. *World J. Biol. Psychiatry.* 3, 96-100, (2002).

113. Cheetham SC, Viggers JA, Slater NA *et al.* [<sup>3</sup>H] Paroxetine binding in rat frontal cortex strongly correlates with [<sup>3</sup>H] 5HT uptake: effect of administration of various antidepressant treatments. *Neuropharmacol.* 32, 737-743, (1993).

114. Bekker EM, Overtom CCE, Kooij JJS *et al.* disentangling deficits in adults with attention-deficit / hyperactivity disorder. *Arch. Gen. Psychiatry* 62, 1129-1136, (2005).

115. Birmaher B, Stanley M, Greenhill L *et al.* Platelet imipramine binding in children and adolescents with impulsive behavior. *J. Am. Acad. Child Adolesc. Psychiatry* 29, 914-918, (1990).

116. Stadler C, Schmeck K, Nowraty I *et al.* Platelet 5-HT Uptake in boys with conduct disorder. *Neuropsychobiol.* 50, 244-251, (2004).

117. van Goozen SHM, Matthys W, Cohen-Kettenis PT *et al.* Plasma monoamine metabolites and aggression: two studies of normal and oppositional defiant disorder children. *Eur. Neuro-psychopharmacol.* 9, 141-147, (2003).

118. Rubia K, Taylor EA, Smith AB *et al.* Neuropsychological analyses of impulsiveness in childhood hyperactivity. *Br. J. Psychiatry* 179, 138-143, (2001).

\* A good summary of the tasks used and the neuroimaging results obtained for the bases of impulsivity in childhood ADHD.

119. Talbot PS. Functional neuroimaging of rapid tryptophan depletion. *J. Psychopharmacol.* 20, A2 S7, (2006)

120. Cahir MC. Effect of acute and chronic tryptophan depletion on serotonergic metabolism and receptors in the rat brain. *J. Psychopharmacol.* 20, A2 S5 (2006).

121. Dalley JW, Theobald DE, Eagle DM *et al.* Deficits in impulse control associated with tonically-elevated serotonergic function in rat prefrontal cortex. *Neuropsychopharmacol.* 26, 716-728, (2002).

\* An important animal study of the role of 5-HT in impulsivity

122. Winstanley CA, Dalley JW, Theobald DEH *et al.* Fractionating impulsivity: contrasting effects of central 5-HT depletion on different measures of impulsive behavior. *Neuropsychopharmacol.* 29, 1331-1343, (2004).

123. Clarke HF, Walker SC, Dalley JW *et al.* Cognitive inflexibility after prefrontal serotonin depletion is behaviorally and neurochemically specific. *Cereb. Cortex*, 17, 18-27, (2005).

124. Antrop I, Stock P, Verte S *et al.* ADHD and delay aversion: the influence of non-temporal stimulation on choice for delayed rewards. *J. Child Psychol. Psychiatry* 47, 1152-1158, (2006)

125. Winstanley CA, Dalley JW, Theobald DE *et al.* Global 5-HT depletion attenuates the ability of amphetamine to decrease impulsive choice on a delay-discounting task in rats. *Psychopharmacol.* 170, 320-331, (2003).

126. Winstanley CA, Theobald DEH, Dalley JW *et al.* Interactions between

serotonin and dopamine in the control of impulsive choice in Rats: therapeutic implications for impulse control disorders. *Neuropsychopharmacol.* 30, 669-682, (2005).

127. Winstanley CA, Theobald DEH, Dalley JW *et al.* Double dissociation between serotonergic and dopaminergic modulation of medial prefrontal and orbitofrontal cortex during a test of impulsive choice. *Cereb. Cortex*, 16, 106-114, (2006).

128. Kalenscher T, Ohmann T, Güntürkün O. The neuroscience of impulsive and self-controlled decisions. *Int. J. Psychophysiol.* 62, 203-211, (2006).

\* A wide ranging account across the animal kingdom of the anatomical and neurotransmitters bases of impulsivity, with special reference to temporal discounting/ delayed gratification.

129. Higley JD, Thompson WW, Champoux M *et al.* Paternal and maternal genetic and environmental contributions to cerebrospinal fluid monoamine metabolites in Rhesus monkeys (*Macaca mulatta*). *Arch. Gen. Psychiatry* 50, 615-623, (1993).

130. Virkkunen, M.; Goldman, D.; Nielsen, D.A. *et al.* Low brain serotonin turnover rate (low CSF 5-HIAA) and impulsive violence. *J. Psychiat. Neurosci.* 20, 271-275, (1995).

131. Comings, D.E.; Gade-Andavolu, R.; Gonzalez, N. *et al.* Multivariate analysis of associations of 42 genes in ADHD, ODD and conduct disorder. *Clin. Genet.* 58, 31-40, (2000).

132. Evenden JL, Ryan CN. The pharmacology of impulsive behaviour in rats. VI: the effects of ethanol and selective serotonergic drugs on response choice with varying delays of reinforcement. *Psychopharmacol.* 146, 413-421, (1999).

\* One of a useful series on the biological bases underlying impulsivity in animals.

133. Li, J.; Wang, Y.; Zhu, R. *et al.* Serotonin 5-HT<sub>1B</sub> Receptor gene and attention deficit hyperactivity disorder in Chinese Han subjects. *Am. J. Med. Genet.* 132B, 59-63, (2005).
134. Sandou F, Amara DA, Dierich A *et al.* Enhanced aggressive behavior in mice lacking 5-HT<sub>1b</sub> receptor. *Science*, 265, 1875-1878, (1994).
135. Dulawa SC, Hen R, Searce-Levie K *et al.* Serotonin<sub>1B</sub> receptor modulation of startle reactivity, habituation and prepulse inhibition in wild-type and serotonin<sub>1B</sub> knockout mice. *Psychopharmacol.* 132, 125-134, (1997).
136. Barot SK, Ferguson SM, Neumaier JF 5-HT<sub>1B</sub> receptors in nucleus accumbens efferents enhance both rewarding and aversive effects of cocaine. *Eur. J. Neurosci.* 25, 3125-3131, (2007).
137. Hawi Z, Dring M, Kirley A *et al.* Serotonergic system and attention deficit hyperactivity disorder (ADHD): a potential susceptibility locus at the 5-HT<sub>1B</sub> receptor gene in 273 nuclear families from a multi-centre sample. *Mol. Psychiatry* 7, 718-725, (2002).
138. Quist JF, Barr CL, Schachar RJ *et al.* The serotonin 5-HT<sub>1B</sub> receptor gene and attention deficit hyperactivity disorder. *Mol. Psychiatry* 8, 98-102 (2003).
139. Ogdie MN, Fisher SE, Yang M *et al.* Attention deficit hyperactivity disorder: fine mapping supports linkage to 5p13, 6q12, 16p13 and 17p11. *Am. J. Hum. Genet.* 75, 661-668 (2004).
140. Smoller JW, Biederman J, Arbeitman L *et al.* Association between the 5HT<sub>1B</sub> receptor gene (*HTR1B*) and the inattentive subtype of ADHD. *Biol. Psychiatry* 59, 460-469, (2006).
141. Bobb AJ, Addington AM, Sidransky E *et al.* Support for association between ADHD and two candidate genes: NET1 and DRD1. *Am. J. Med. Genet.* 134B, 67-72, (2005)
142. Heiser P, Dempfle A, Friedel S *et al.* Family-based association study of serotonergic candidate genes and attention-deficit/hyperactivity disorder in a German sample. *J. Neur. Transm.* 114, 513-21 (2007).
143. Ickowicz A, Feng Y, Wigg K *et al.* The serotonin receptor HTR1B: gene polymorphisms in attention deficit hyperactivity disorder. *Am. J. Hum. Genet.* 144B, 121-124 (2007).
144. Barone P, Jordan D, Atger F *et al.* Quantitative autoradiography of 5-HT<sub>1D</sub> and 5-HT<sub>1E</sub> binding sites labelled by [<sup>3</sup>H]5-HT, in frontal cortex and the hippocampal region of the human brain. *Brain Res.* 638, 85-94, (1994).
145. Quist JF, Barr CL, Schachar RJ *et al.* Evidence for the serotonin HTR2A receptor gene as a susceptibility factor in attention deficit hyperactivity disorder (ADHD). *Mol. Psychiatry* 5, 537-541, (2000).
146. Galili-Weisstub E, Segman RH. Attention deficit and hyperactivity disorder: review of genetic association studies. *Isr. J. Psychiatr. Rel. Sci.* 40, 57-66, (2003).
147. Guimara APM, Zeni C, Polanczyk GV *et al.* Serotonin genes and attention deficit/ hyperactivity disorder in a Brazilian sample: preferential transmission of the HTR2A 452His allele to affected boys. *Am. J. Med. Genet.* 144B, 69-73, (2007).
148. Su L, Cheng D, Gao X. Association of the 5-HT<sub>2A</sub> receptor polymorphism and attention deficit hyperactivity disorder (ADHD). *Proc. 16<sup>th</sup> World Congr. of IACAPAP*, August, Berlin, p.169 (2004).
149. Reuter M, Kirsch P, Hennig J. Inferring candidate genes for Attention Deficit Hyperactivity Disorder (ADHD)

assessed by the World Health Organization Adult ADHD Self-Report Scale (ASRS). *J. Neur. Transm.* 113, 929-938, (2007).

150. Li J, Knag C, Wang Y *et al.* Contribution of 5-HT<sub>2A</sub> receptor gene -1438A>G polymorphism to outcome of attention-deficit/hyperactivity disorder in adolescents. *Am. J. Med. Genet.* 141B, 473-476, (2006).

151. Li J, Wang Y, Zhou R *et al.* Association between polymorphisms in serotonin 2C receptor gene and attention-deficit/hyperactivity disorder in Han Chinese subjects. *Neurosci. Lett.* 407, 107-111, (2006).

152. Alex KD, Yavarian GJ, McFarlane HG *et al.* Modulation of dopamine release by striatal 5-HT<sub>2C</sub> receptors. *Synapse*, 55, 242-251, (2005).

153. Bubar MJ, Cunningham KA. Distribution of serotonin 5-HT<sub>2C</sub> receptors in the ventral tegmental area. *Neurosci.* 146, 286-297, (2007).

154. Stiedl O, Misane I, Koch M *et al.* Activation of the brain 5-HT<sub>2C</sub> receptors causes hypo-locomotion without anxiogenic-like cardiovascular adjustments in mice. *Neuropharmacol.* 52, 949-957, (2007).

155. Li J, Wang Y, Zhou R *et al.* Association of attention-deficit/hyperactivity disorder with serotonin 4 receptor gene polymorphisms in Han Chinese subjects. *Neurosci. Lett.* 401, 6-9, (2006).

156. Lucas G, Compan V, Charnay Y *et al.* Frontocortical 5-HT<sub>4</sub> receptors exert positive feedback on serotonergic activity: Viral transfections, subacute and chronic treatments with 5-HT<sub>4</sub> agonists. *Biol. Psychiat.* 57, 918-925, (2005).

157. Micale V, Leggio GM, Mazzola C *et al.* Cognitive effects of SL65.0155, a

serotonin 5-HT<sub>4</sub> receptor partial agonist, in animal models of amnesia. *Brain Res.* 1121, 207-215, (2006).

158. Varnäs K, Halldin C, Pike VW *et al.* Distribution of 5-HT<sub>4</sub> receptors in the postmortem human brain — an autoradiographic study using [<sup>125</sup>I]SB 207710. *Eur. Neuropsychopharmacol.* 13, 228-234, (2003).

159. Paolucci E, Berretta N, Tozzi A *et al.* Depression of mGluR-mediated IPSCs by 5-HT in dopamine neurons of the rat substantia nigra pars compacta. *Eur. J. Neurosci.* 13, 2743-2650, (2003).

160. Li J, Wang Y, Zhou R *et al.* No association of attention-deficit / hyperactivity disorder with genes of the serotonergic pathway in Han Chinese subjects. *Neurosci. Lett.* 403, 172-175, (2006).

161. Sheehan K, Hawi Z, Gill M *et al.* No association between TPH2 gene polymorphisms and ADHD in a UK sample. *Neurosci. Lett.* 412, 105-107, (2007).

162. Reuter M, Ott U, Vaitl D *et al.* Impaired executive control associated with a variation in the tryptophan hydroxylase-2 gene. *J. Cogn. Neurosci.* 19, 401-408, (2007).

163. Canli T, Omura K, Haas BW *et al.* Beyond affect: a role for genetic variation of the serotonin transporter in neural activation during a cognitive attention task. *Proc. Natl. Acad. Sci. (USA)* 102, 12224–12229, (2005).

164. Manor I, Eisenberg J, Tyano S *et al.* Family-based association study of the serotonin transporter promoter region polymorphism (5-HTTLPR) in attention deficit hyperactivity disorder. *Am. J. Med. Genet.* 105, 91-95, (2001).

165. Zoroglu SS, Erdal ME, Alasehirli B *et al.* Significance of serotonin transporter gene 5-HTTLPR and variable number of tandem repeat polymorphism in attention

deficit hyperactivity disorder. *Neuropsychobiol.* 41, 176-181, (2002).

166. Kent L, Doerry U, Hardy E, *et al.* 2002. Evidence that variation at the serotonin transporter gene influences susceptibility to attention deficit hyperactivity disorder (ADHD): Analysis and pooled analysis. *Mol. Psychiatry* 7, 908–912, (2002).

167. Langley K, Payton A, Hamshere ML, *et al.* 2003. No evidence of association of two 5HT transporter gene polymorphisms and attention deficit hyperactivity disorder. *Psychiatr. Genet.* 13, 107–110, (2003).

168. Seeger G, Schloss P, Schmidt MH. Marker gene polymorphisms in hyperkinetic disorder - predictors of clinical response to treatment with methylphenidate? *Neurosci. Lett.* 313, 45-48, (2001).

169. Seeger G, Schloss P, Schmidt MH *et al.* Gene-environment interaction in hyperkinetic conduct disorder (HD + CD) as indicated by season of birth variations in dopamine receptor (DRD4) gene polymorphism. *Neurosci. Lett.* 366, 282-286, (2004).

170. Wigg KG, Takhar A, Ickowicz A *et al.* Gene for the serotonin transporter and ADHD: No association with two functional polymorphisms. *Am. J. Med. Genet.* 141B, 566-570, (2006).

171. Schalling D, Asberg M, Edman G *et al.* Markers for vulnerability to psychopathology: temperament traits associated with platelet MAO activity. *Acta Psychiat. Scand.* 76, 172-182, (1987).

172. Meyer-Lindenberg AS, Buckholtz JW, Kolachana B *et al.* Neural mechanisms of genetic risk for impulsivity and violence in humans. *Proc. Natl. Acad. Sci. (USA)* 103, 6269-6274, (2006).

173. Jiang S, Xin R, Lin S *et al.* Linkage studies between attention-deficit /

hyperactivity disorder and the monoamine oxidase genes. *Am. J. Med. Genet.* 105, 783-788, (2001).

174. Domschke K, Sheehan K, Lowe N *et al.* Association Analysis of the Monoamine Oxidase A and B Genes With Attention Deficit Hyperactivity Disorder (ADHD) in an Irish Sample: Preferential Transmission of the MAO-A 941G Allele to Affected Children. *Am. J. Med. Genet.* 134B, 110-114, (2005).

175. Das M, Bhowmik AD, Sinha S *et al.* MAOA Promoter Polymorphism and Attention Deficit Hyperactivity Disorder (ADHD) in Indian Children. *Am. J. Med. Genet.* 141B, 637-642, (2006).

176. Lawson DC, Turie D, Langley K *et al.* Association analysis of monoamine oxidase A and attention deficit hyperactivity disorder. *Am. J. Med. Genet.* 116B, 84-89, (2003).

177. Lung F-W, Yang P, Cheng T-S *et al.* No Allele Variation of the MAOA Gene Promoter in Male Chinese Subjects with Attention Deficit Hyperactivity Disorder. *Neuropsychobiol.* 54, 147-151, (2006).

178. Thapar, A.; Langley, K.; Asherson, P. *et al.* Gene - environment interplay in attention-deficit hyperactivity disorder and the importance of a developmental perspective. *Br. J. Psychiatry* 190, 1-3, (2007).

179. Xu X, Brookes K-J, Chen C-K *et al.* Association study between the monoamine oxidase A gene and attention deficit hyperactivity disorder in Taiwanese samples. *BMC Psychiatry* 7, 10, (2007).

180. Manor I, Tyano S, Mel E *et al.* Family based and association studies of monoamine oxidase A and attention deficit hyperactivity disorder (ADHD): preferential transmission of the long promoter-region repeat and its association with impaired performance on

a continuous performance test (TOVA). *Mol. Psychiatry* 7, 626-632, (2002).

181. Gade R, Muleman D, Blake H *et al.* Correlation of length of VNTR alleles at the X-linked MAO-A gene and phenotypic effect in Tourette syndrome and drug abuse. *Mol. Psychiatry* 3, 50-60, (1998).

182. Caspi A, McClay J, Moffitt TE *et al.* Role of genotype in the cycle of violence in maltreated children. *Science* 297, 851-855, (2002).

183. Manuck SB, Flory JD, Ferrell RE *et al.* A regulatory polymorphism of the monoamine oxidase-A gene may be associated with variability in aggression, impulsivity, and central nervous system serotonergic responsivity. *Psychiatry Res.* 95, 9-23, (2000).

184. Passamonti L, Fera F, Magariello A *et al.* Monoamine Oxidase-A genetic variations influence brain activity associated with inhibitory control: new-insight into the neural correlates of impulsivity. *Biol. Psychiatry* 59, 334-340, (2006).

185. Oades RD. Function and dysfunction of monoamine interactions in children and adolescents with AD/HD. In: *Neurotransmitter interactions and cognitive function*, Levin ED (Eds.), Birkhauser Verlag, Basel, 207-244, (2006).

\* This is an extensive review of the interactions of the monoamines emphasizing the neurobiological bases at the synapse, the networks involved and their relevance to dysfunction in ADHD

186. Bonnin A, Torii M, Wang L *et al.* Serotonin modulates the response of embryonic thalamocortical axons to netrin-1. *Nature Neurosci.* 10, 588-597, (2007).

187. Ichise M, Vines DC, Gura T *et al.* Effects of early life stress on [<sup>11</sup>C]DASB positron emission tomography imaging of serotonin transporters in adolescent peer-

and mother-reared Rhesus Monkeys. *J. Neurosci.* 26, 4638-4643, (2006).

188. Slotkin TA, Ryde IT, Tate CA *et al.* Lasting effects of nicotine treatment and withdrawal on serotonergic systems and cell signalling in rat brain regions: Separate or sequential exposure during fetal development and adulthood. *Brain Res. Bull.* 73, 259-272, (2007).

189. Macri S, Spinelli S, Adriani W *et al.* Early adversity and alcohol availability persistently modify serotonin and hypothalamic-pituitary-adrenal-axis metabolism and related behavior: What experimental research on rodents and primates can tell us. *Neurosci. Biobehav. Rev.* 31, 172-180, (2007).

190. Schmitz M, Denardin D, Laufer Silva T *et al.* Smoking during pregnancy and attention-deficit / hyperactivity disorder, predominantly inattentive type: A case-control study. *J. Am. Acad. Child Adolesc. Psychiatry* 45, 1338-1345, (2006).

191. Elgen I, Bruaroy S, Laegreid LM. Lack of recognition and complexity of foetal alcohol neuroimpairments. *Acta Paediatr.* 96, 237-241, (2006).

192. Russell VA, Oades RD, Tannock R *et al.* Response variability in attention-deficit/ hyperactivity disorder: a neuronal and glial energetics hypothesis. *Behav. Brain Funct.* 2, 30, (2006).

\*\* A major hypothesis is proposed to explain two core problems in ADHD, - behavioral variability and delayed development. The explanation is based on the energy supply to neurons from astrocytes and precursors from oligodendrocytes.

193. Uehara T, Sumiyoshi T, Matsuoka T *et al.* Role of 5-HT<sub>1A</sub> receptors in the modulation of stress-induced lactate metabolism in the medial prefrontal cortex and basolateral amygdala. *Psychopharmacol.* 186, 218-225, (2006).

194. Hirst WD, Cheung NY, Rattray M *et al.* Cultured astrocytes express messenger RNA for multiple serotonin receptor subtypes, without functional coupling of 5-HT1 receptor subtypes to adenylyl cyclase. *Mol. Brain Res.* 61, 90-99, (1998).

195. Magistretti PJ, Sorg O, Yu N *et al.* Neurotransmitters regulate energy metabolism in astrocytes: implications for the metabolic trafficking between neural cells. *Dev. Neurosci.* 15, 306-312, (1993).

196. Whitaker-Azmitia PM, Azmitia EC. Astroglial 5-HT1a receptors and S-100 beta in development and plasticity. *Perspect. Dev. Neurobiol.* 2, 233-238, (1994).

197. Steiner J, Bernstein H-G, Biela H *et al.* Evidence for a wide extra-astrocytic distribution of S100B in human brain. *BMC Neurosci.* 8, 2 (2007).

198. Druse MJ, Gillespie RA, Tajuddin NF *et al.* S100B-mediated protection against the pro-apoptotic effects of ethanol on fetal rhombencephalic neurons. *Brain Res.* 1150, 46-54, (2007).

199. Gobert, A.; Rivet, J-M.; Audinot, V. *et al.* Simultaneous quantification of serotonin, dopamine and noradrenaline levels in single frontal cortex dialysates of freely-moving rats reveals a complex pattern of reciprocal auto- and heteroreceptor-mediated control of release. *Neurosci.* 84, 413-429, (1998).



